

V3S 1/10 RC chassis

A few words about the building
I use PLA (Plasty Mladeč)

I recommend a layer of 0.2 mm, just 40% fill.
For axle use 5 perimeters



Step 1

MAKE 4x

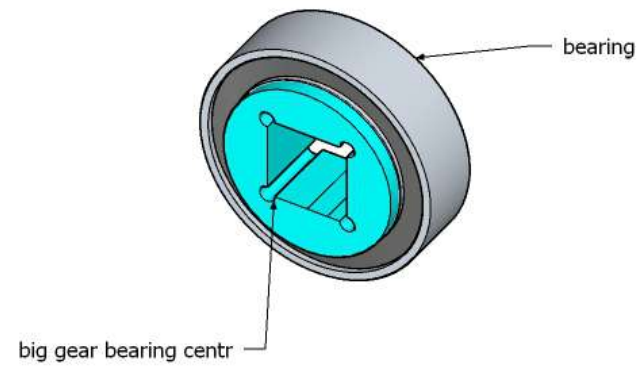

Step 2

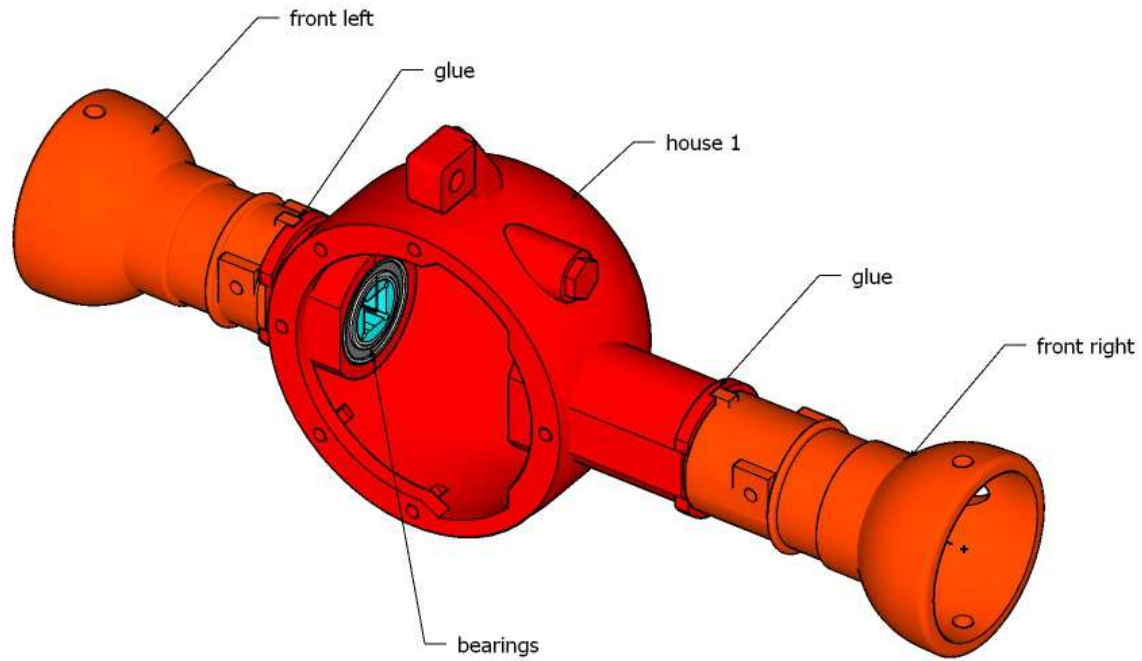

Step 3

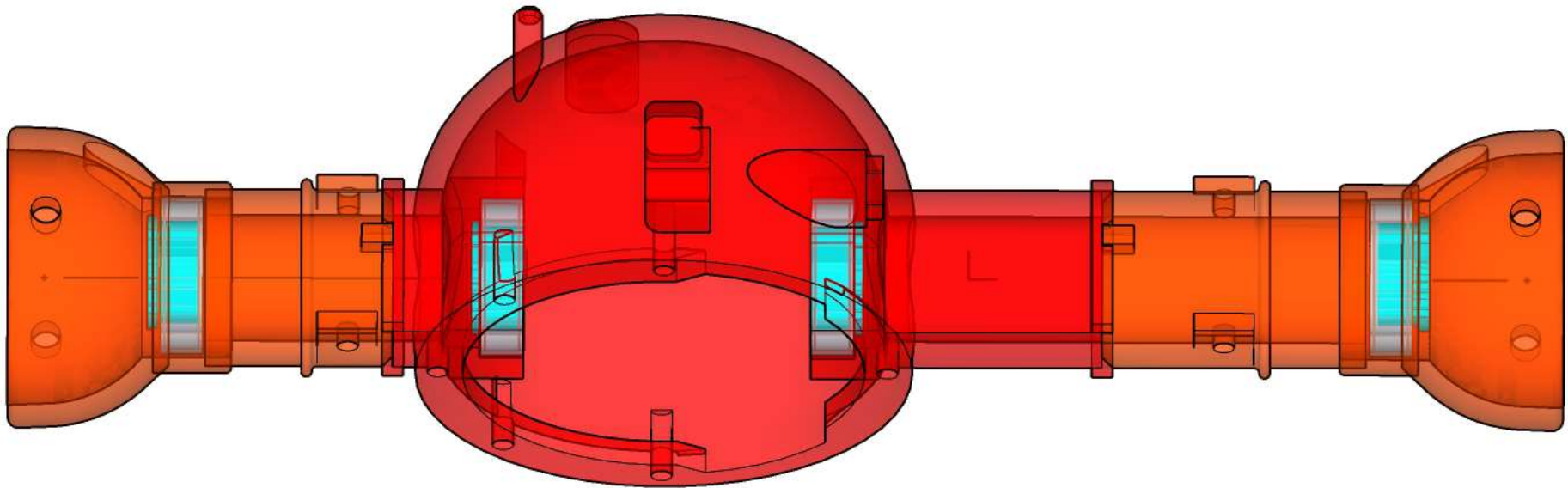

Step 4

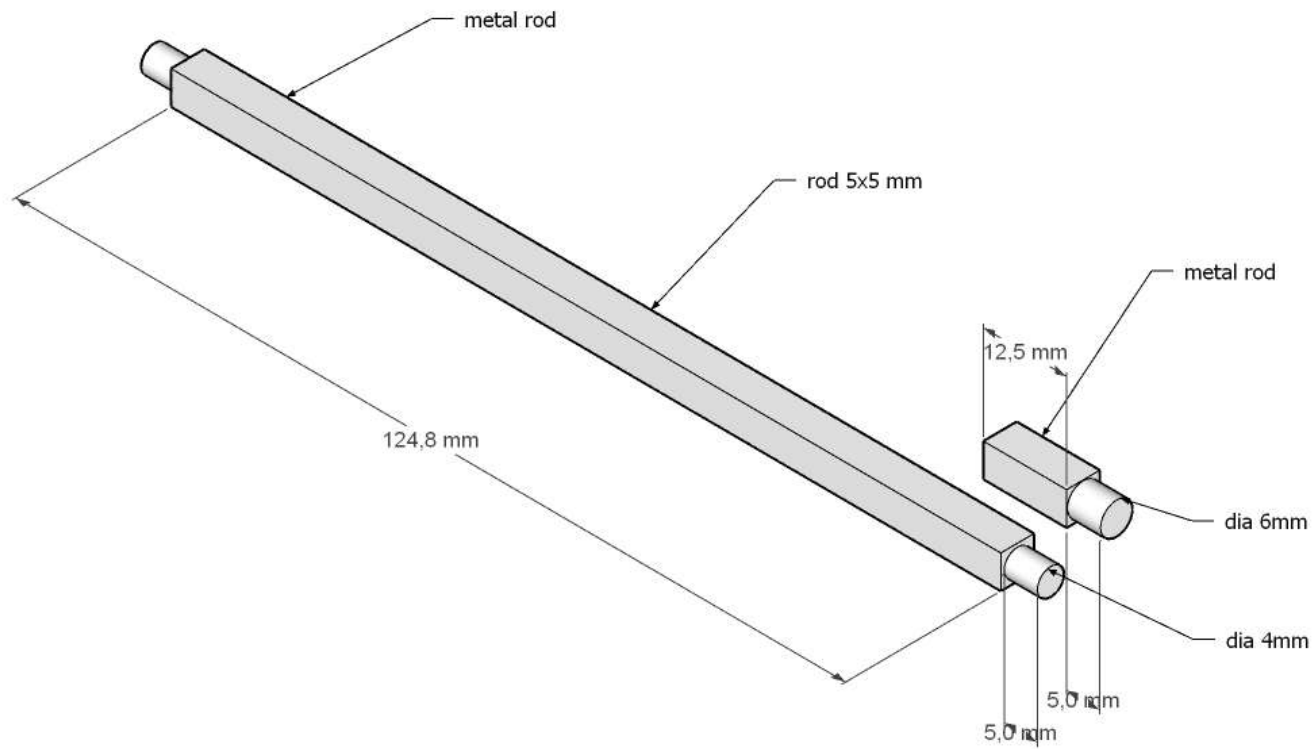

Step 5

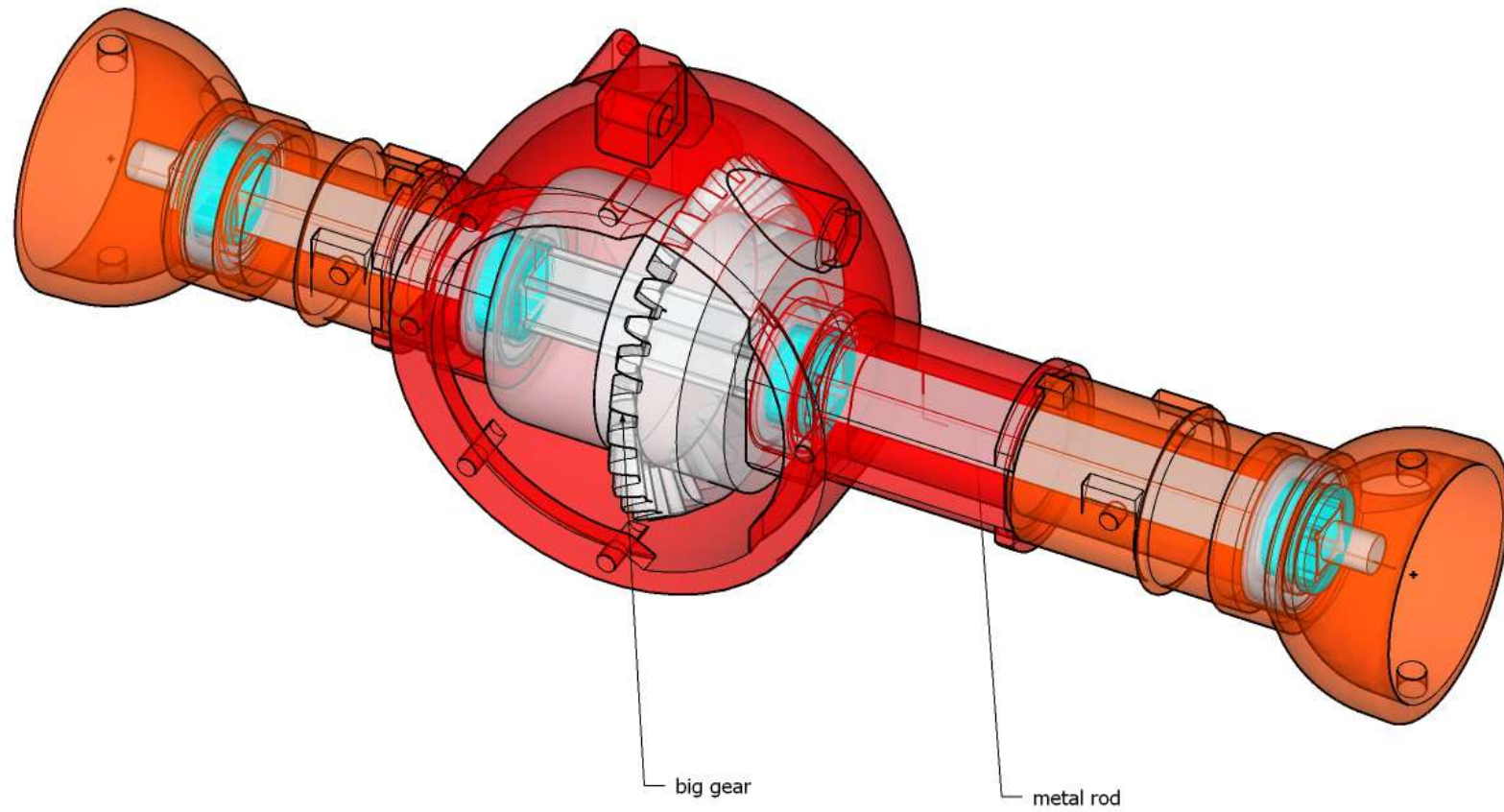

Step 6

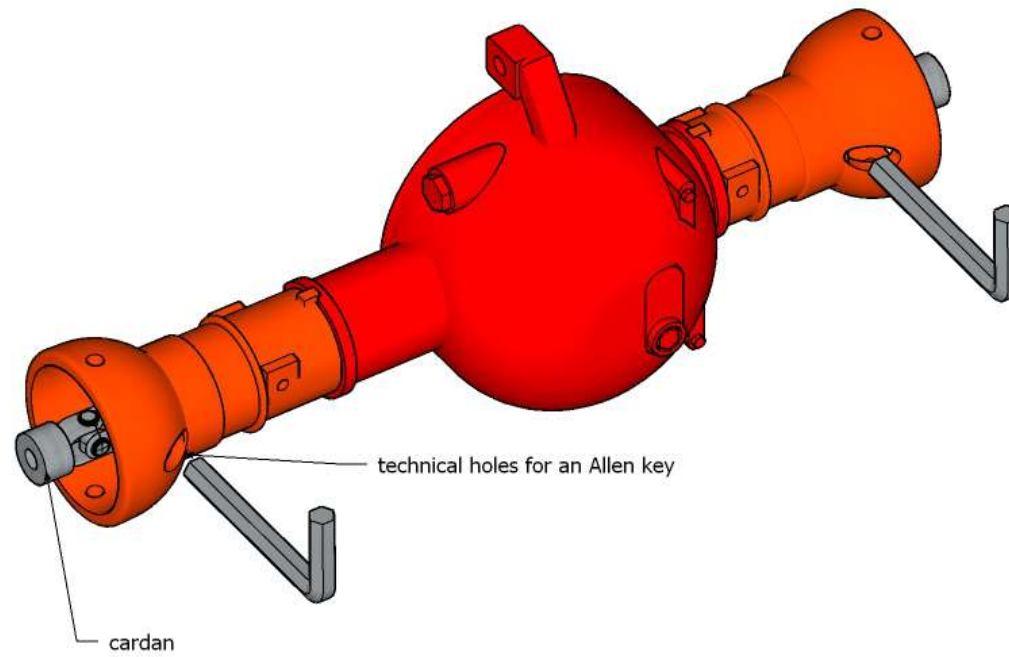

Step 7

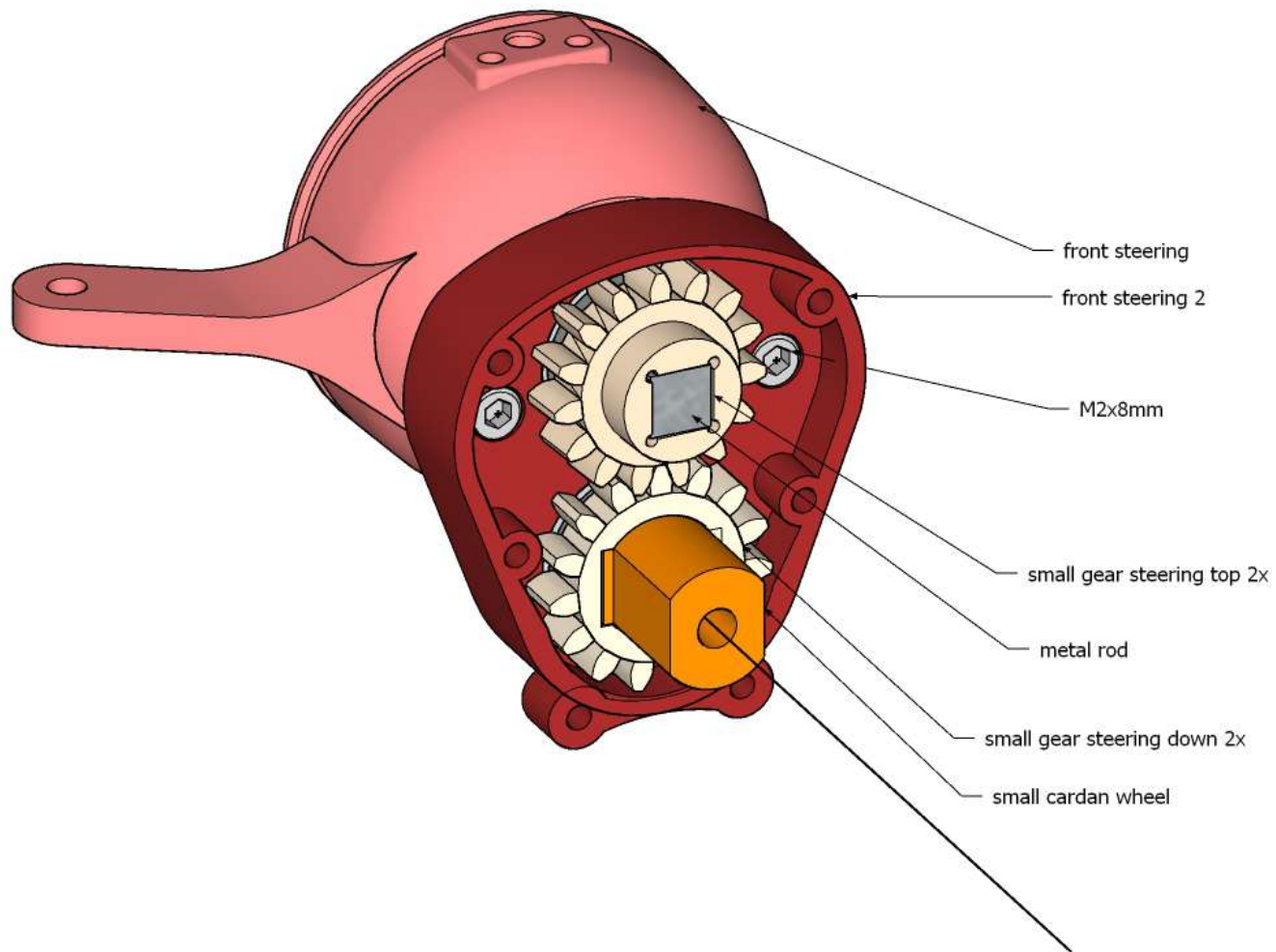

Step 8

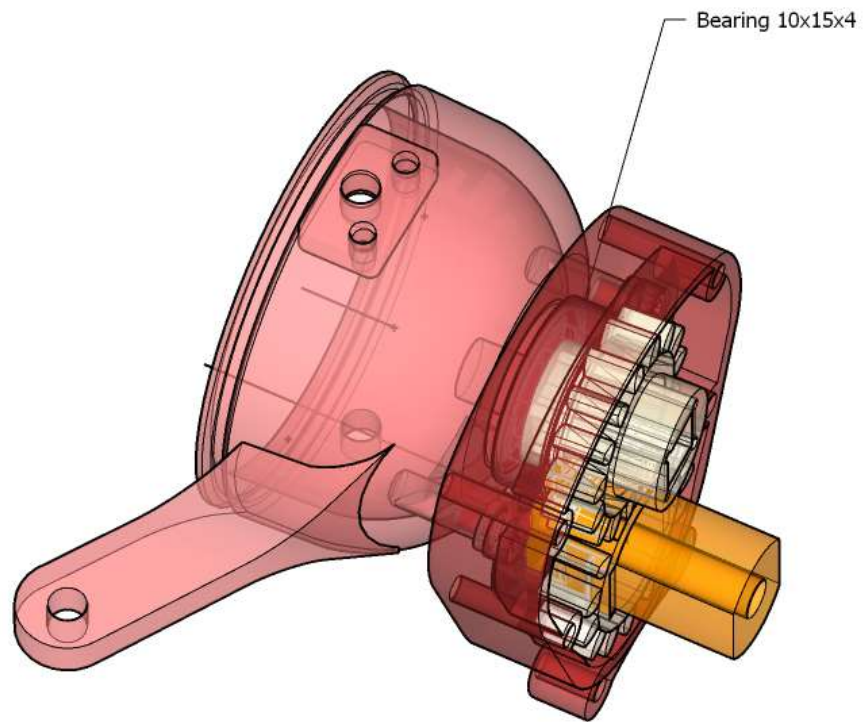

Step 9

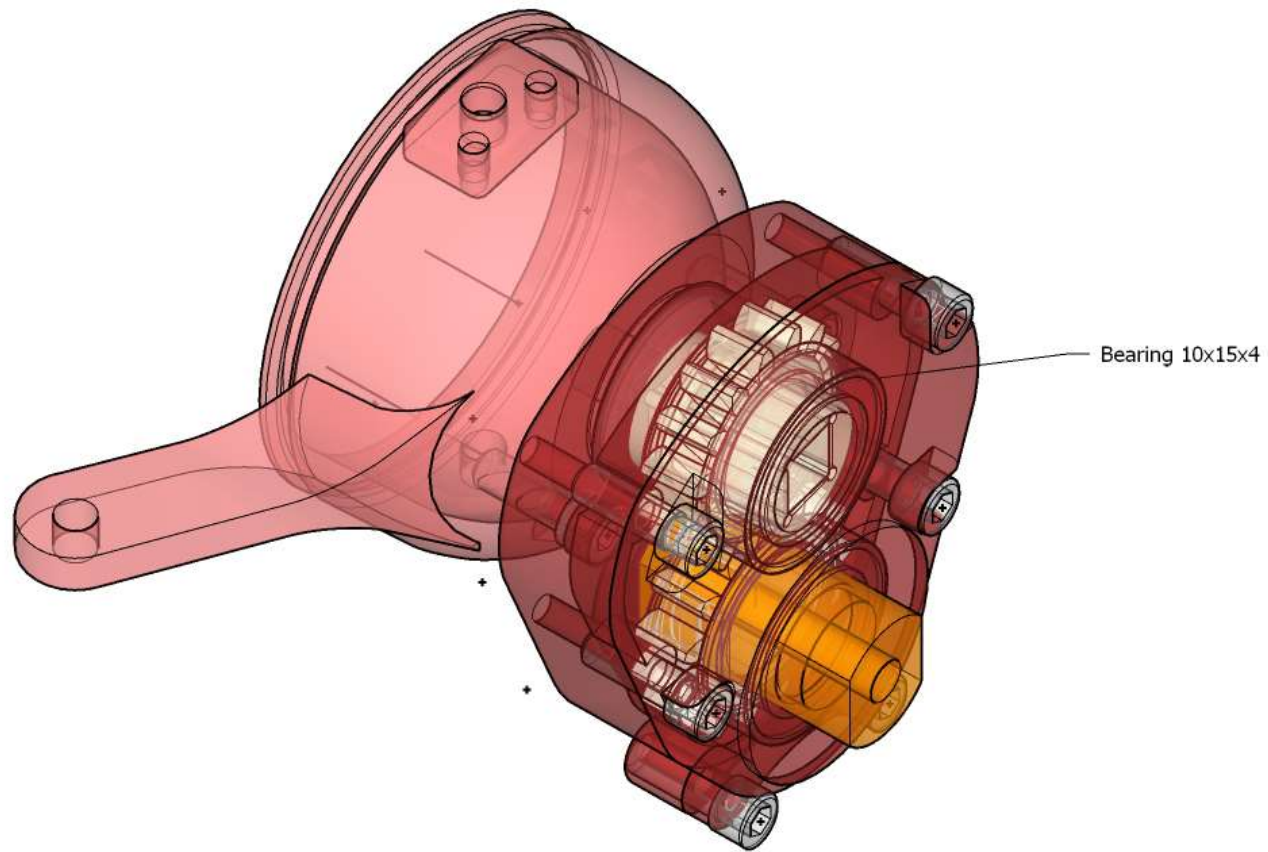

Step 10

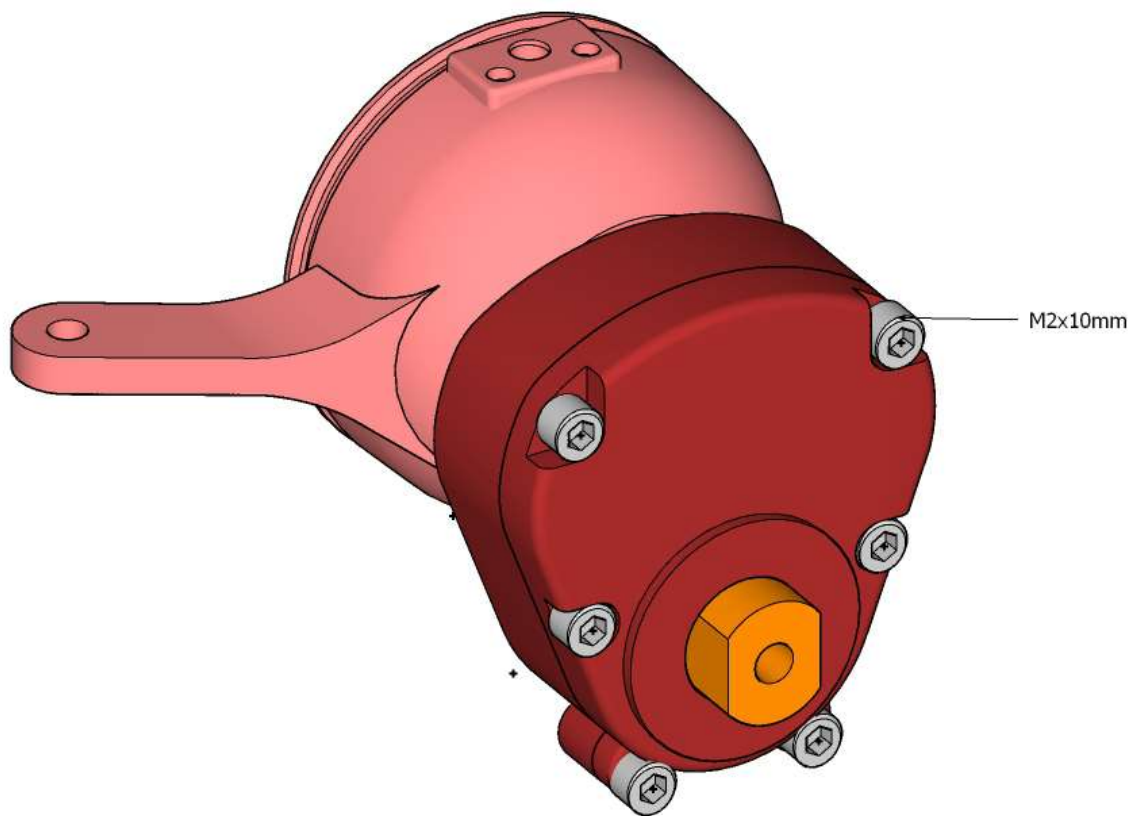

Step 11

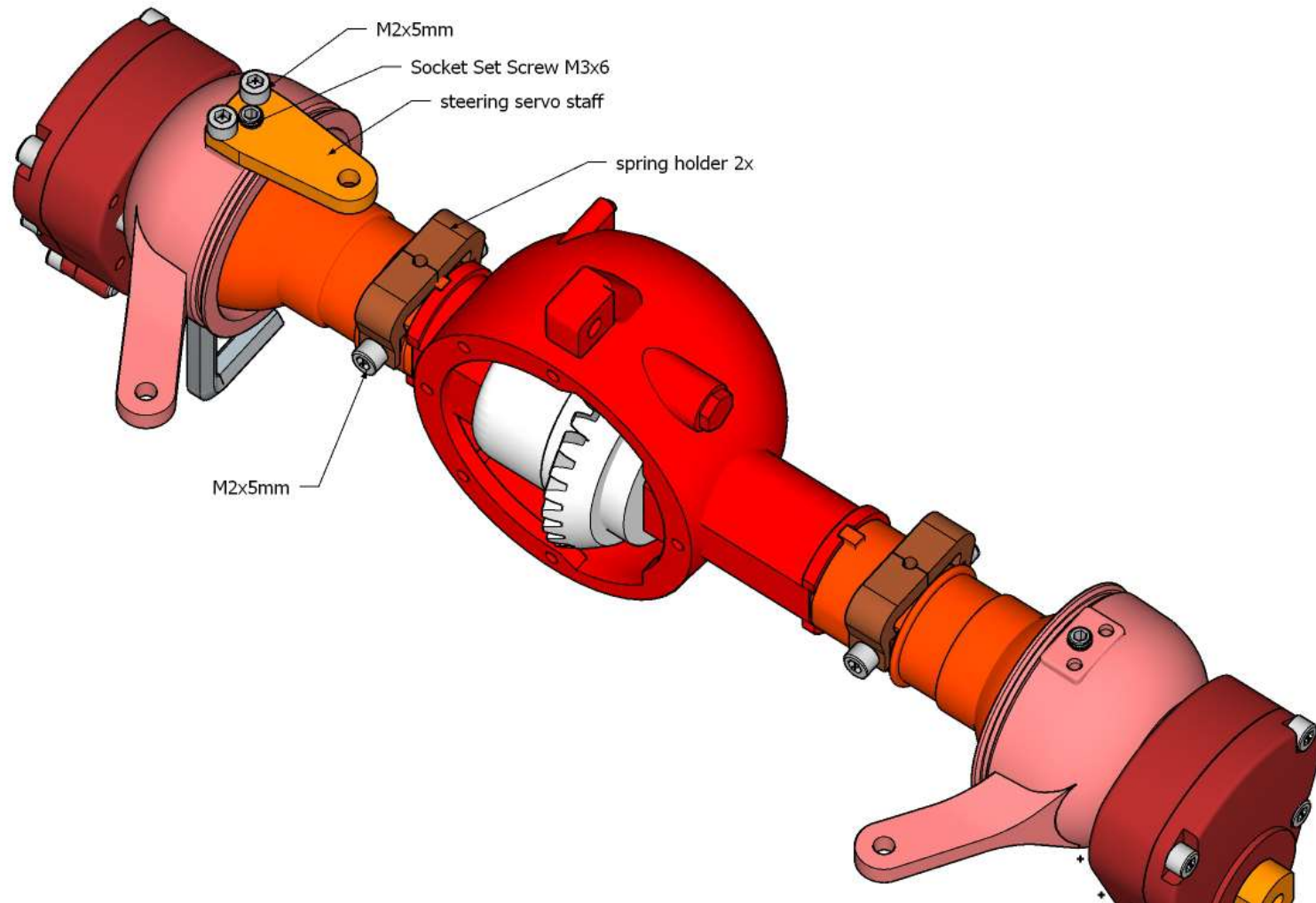

Step 12

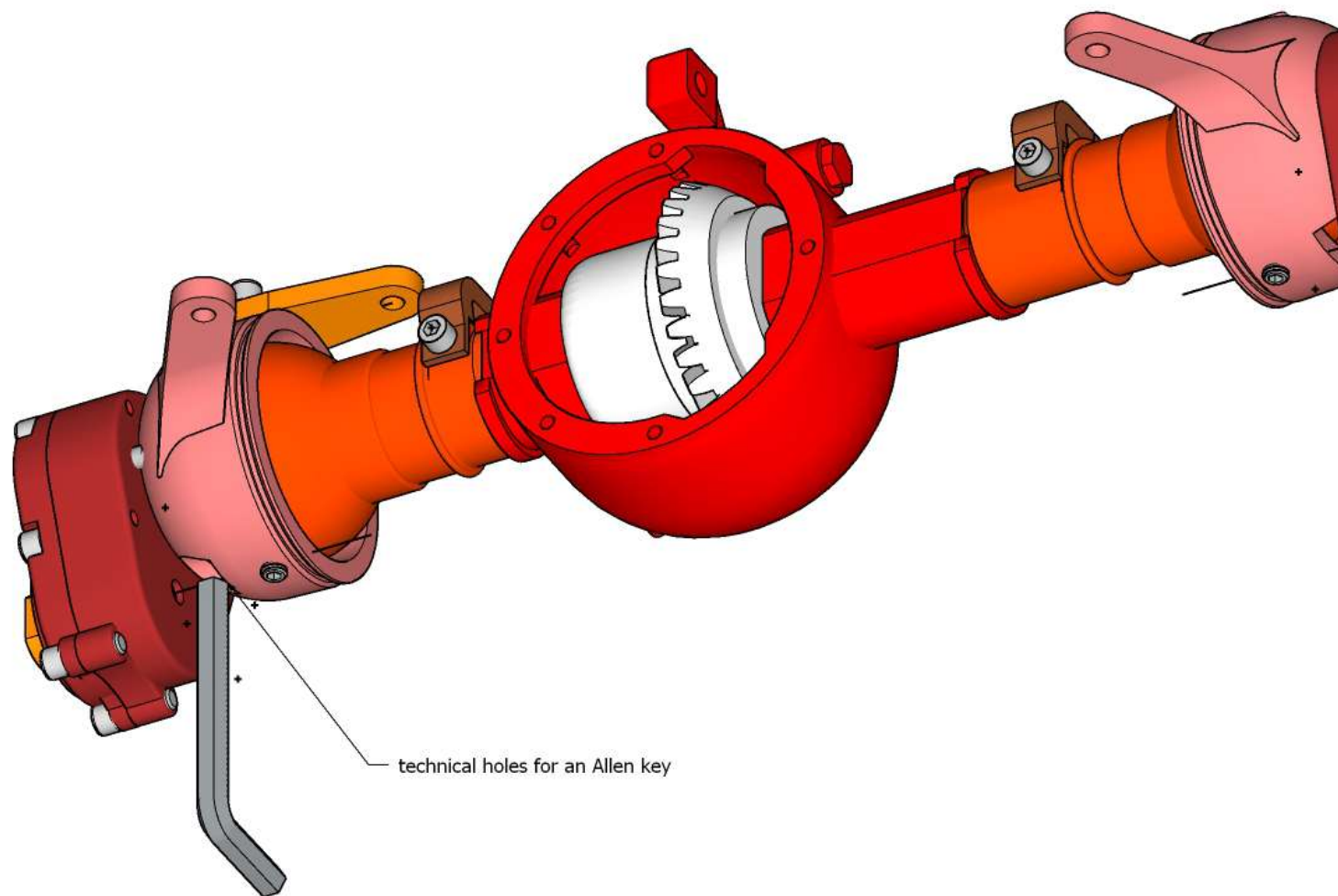

Step 13

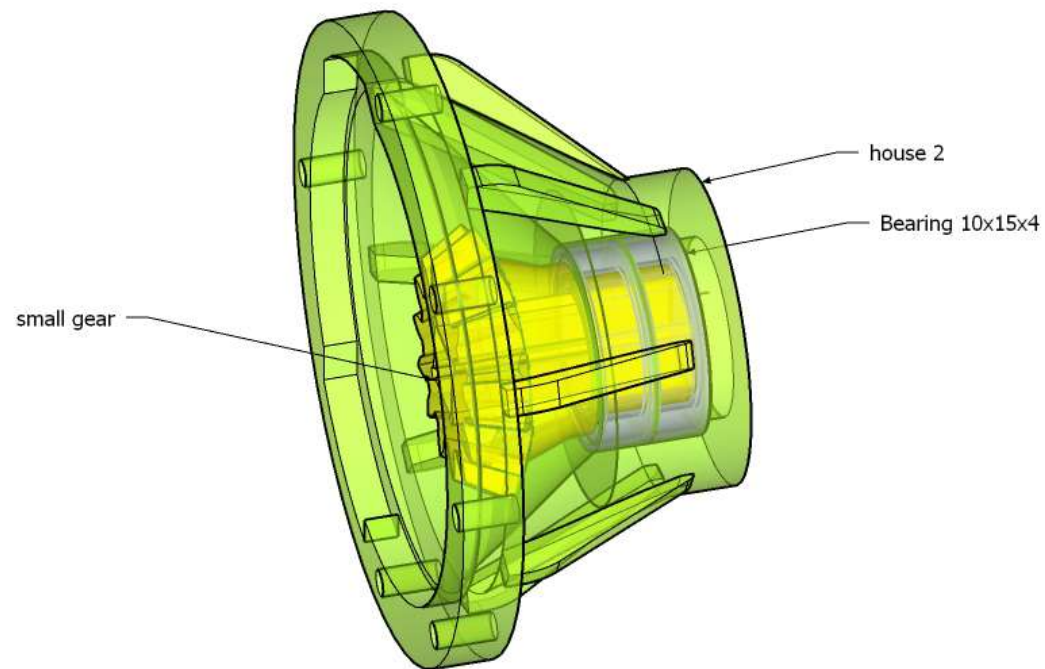

Step 14

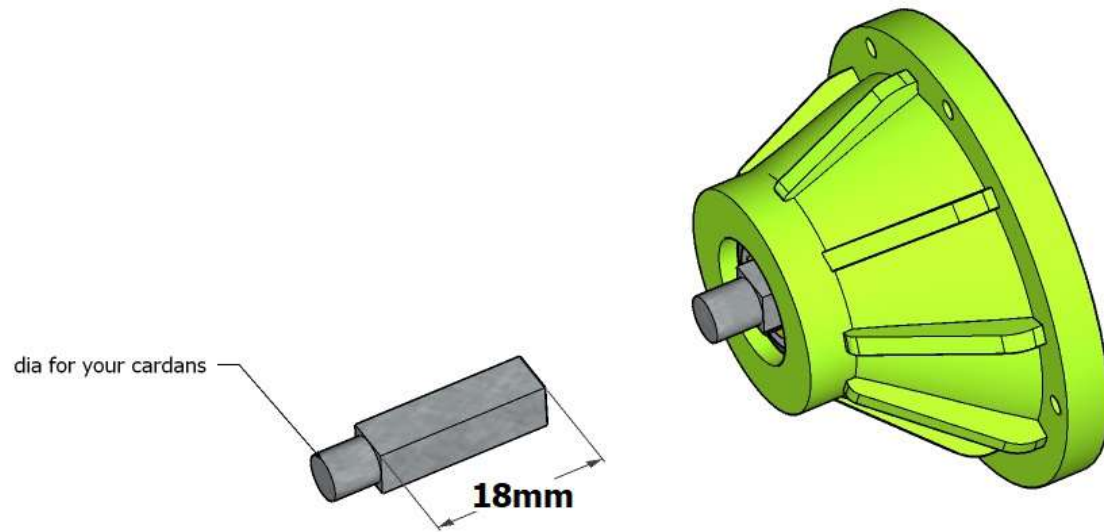

Step 15

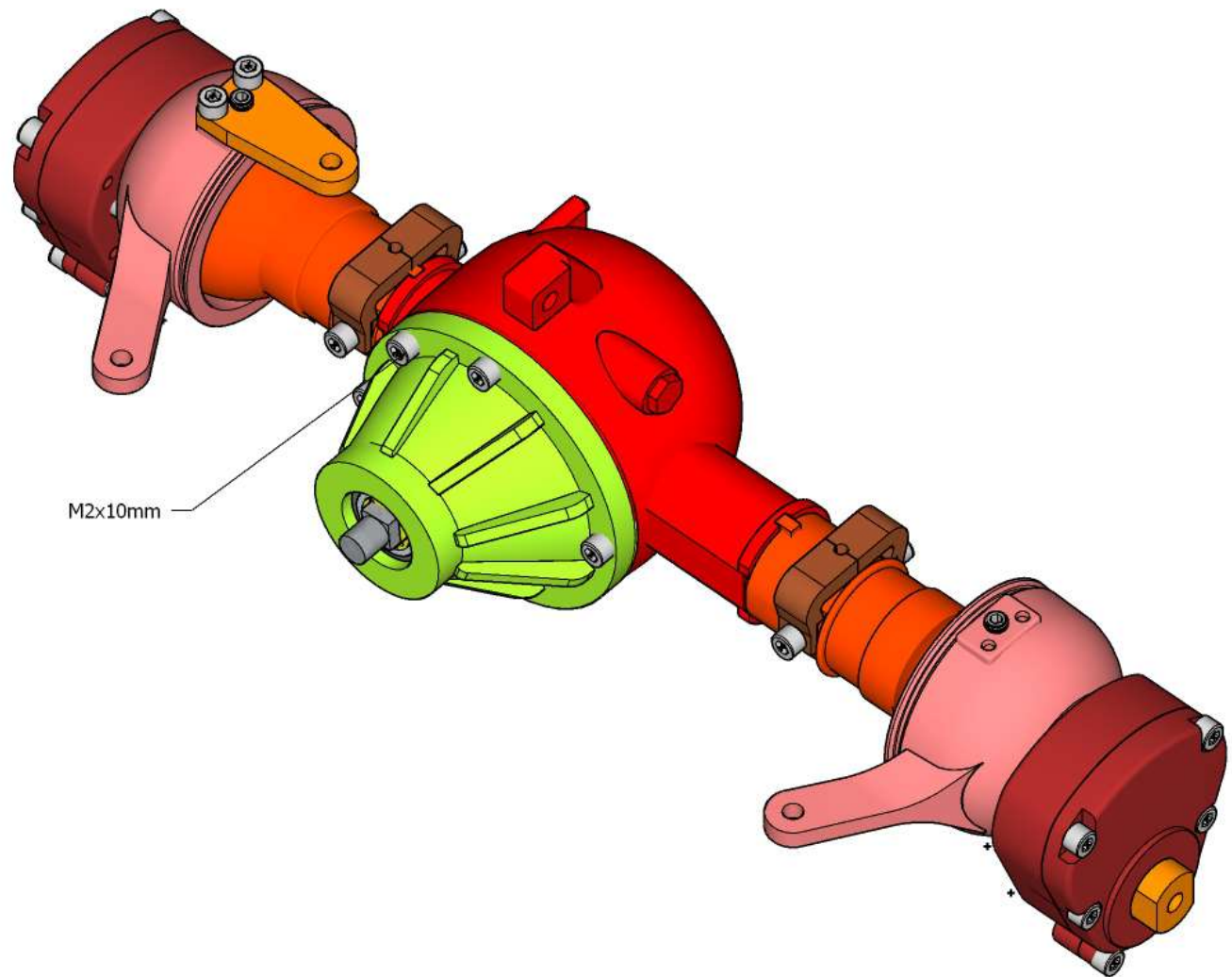

Step 16

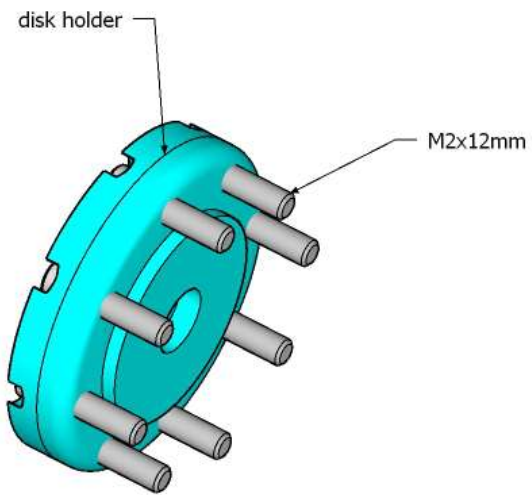

Step 17

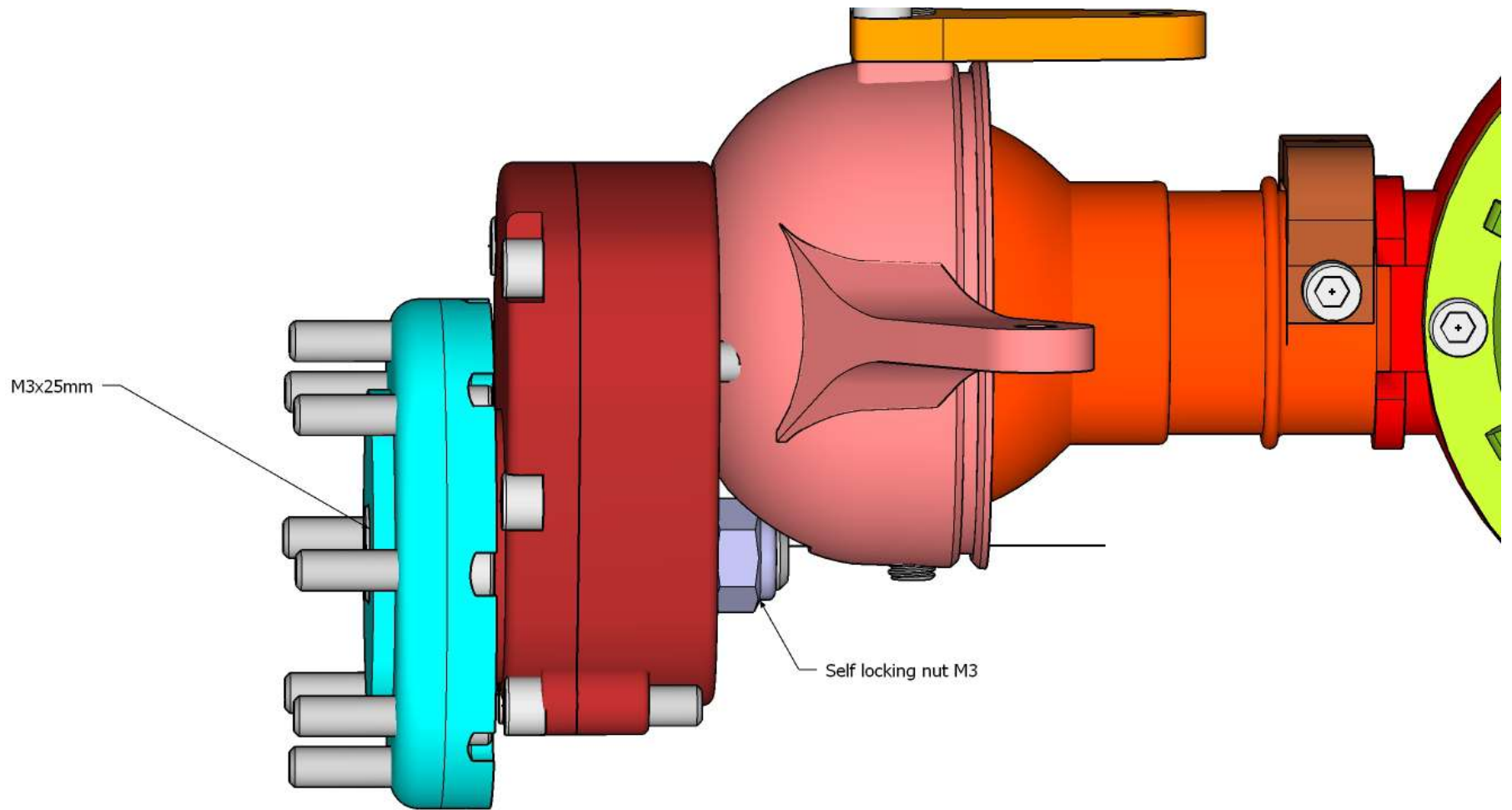

Step 18

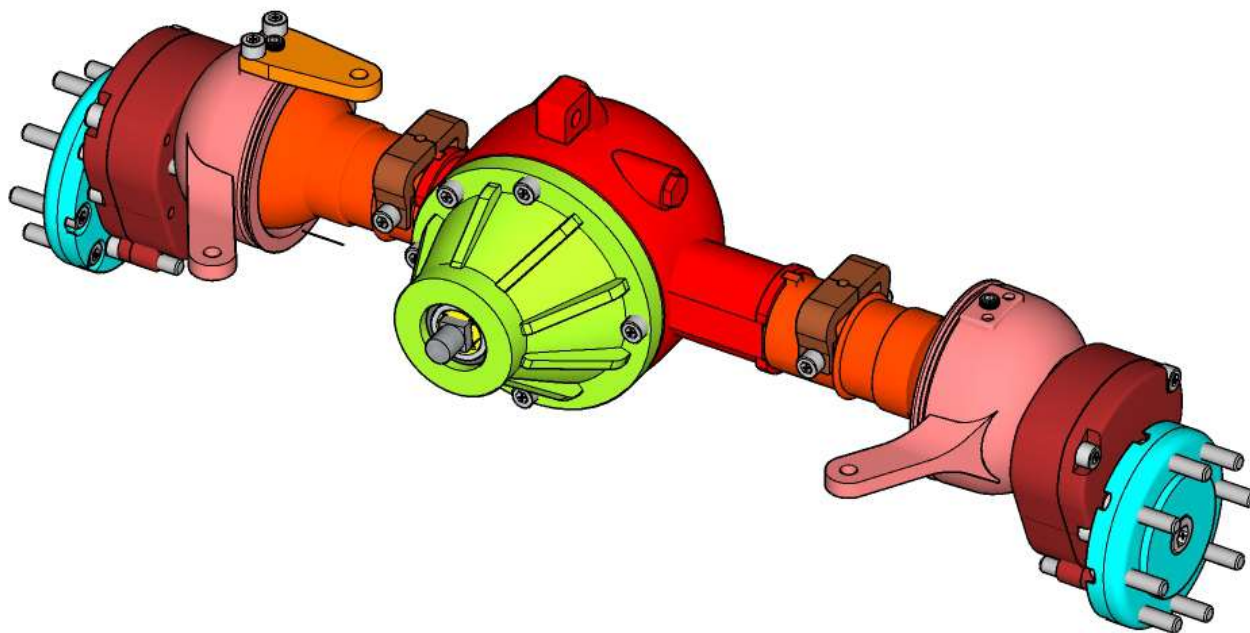

Step 19

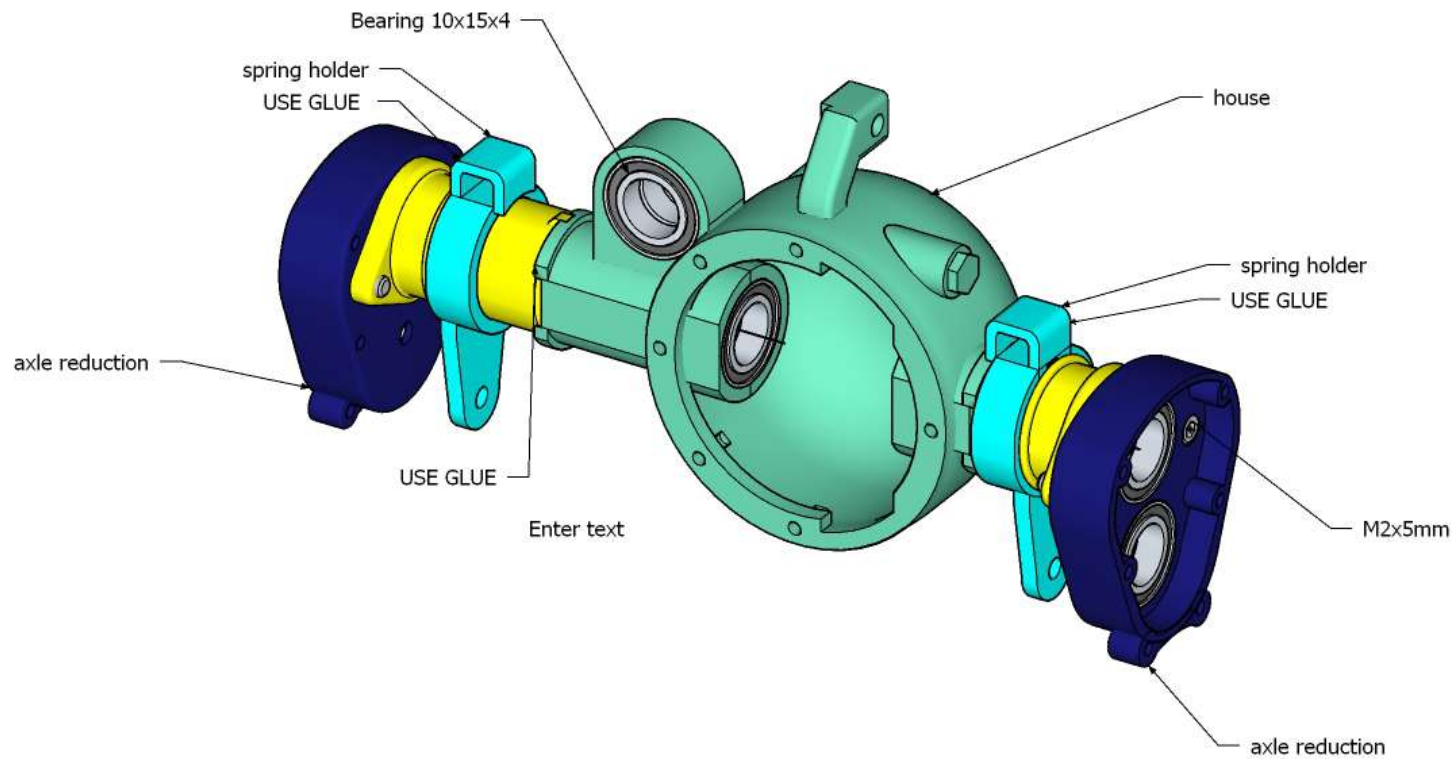

Step 20

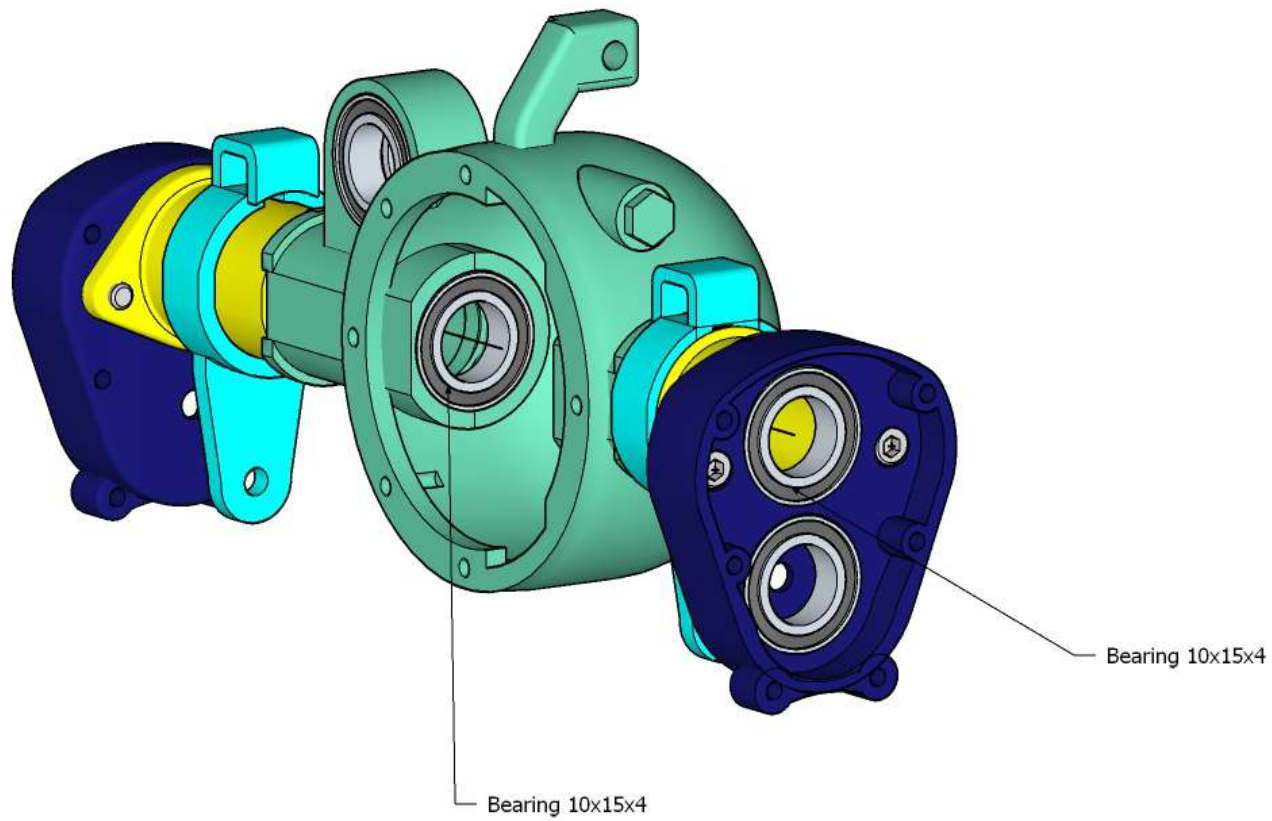

Step 21

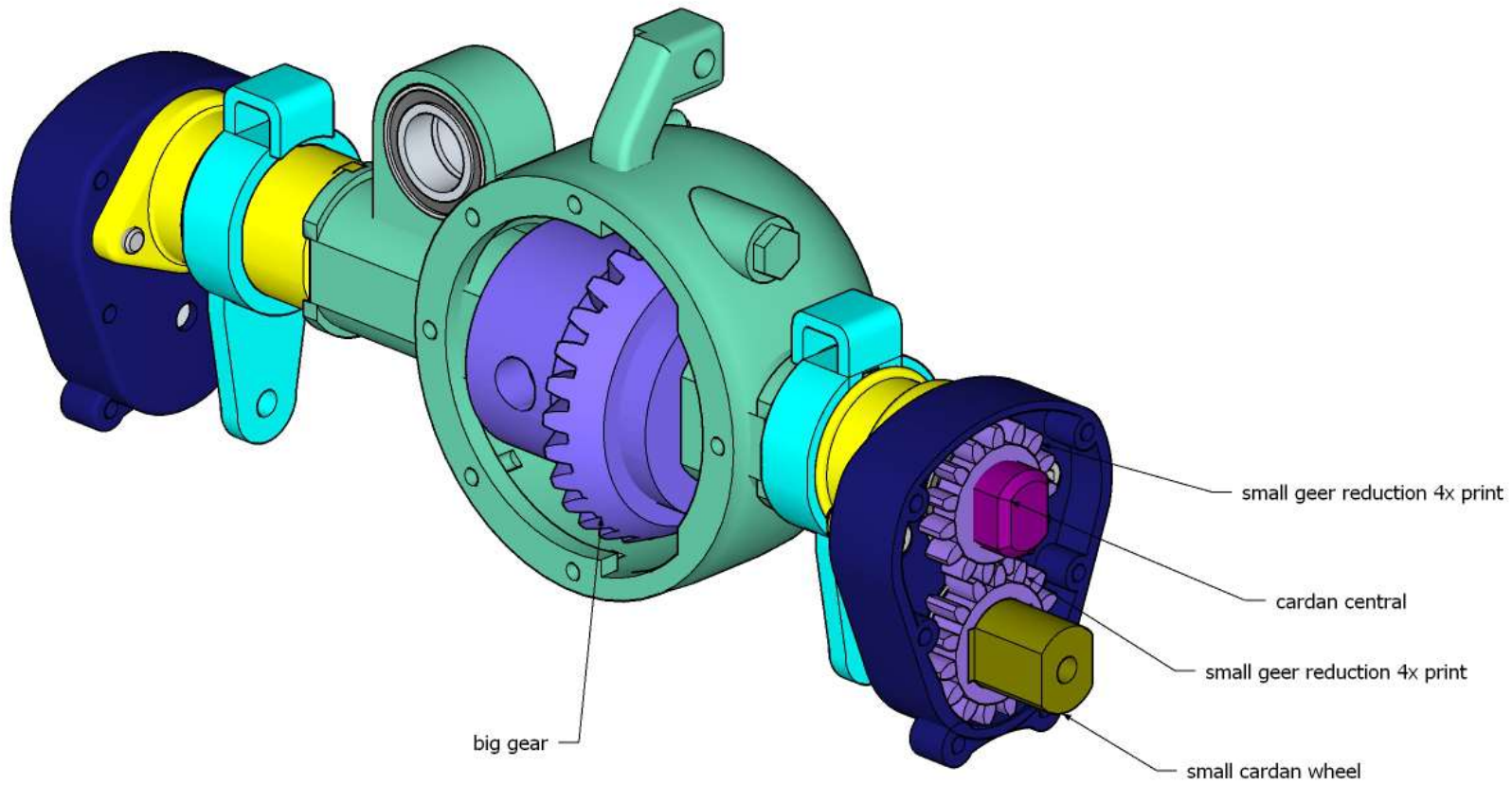

Step 22

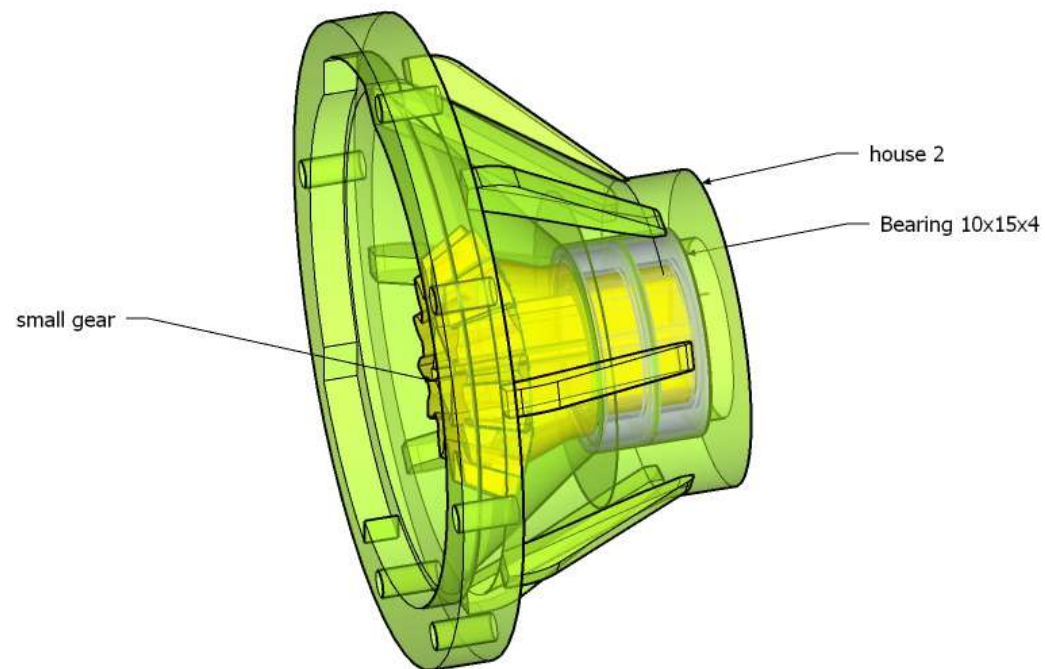

Step 23

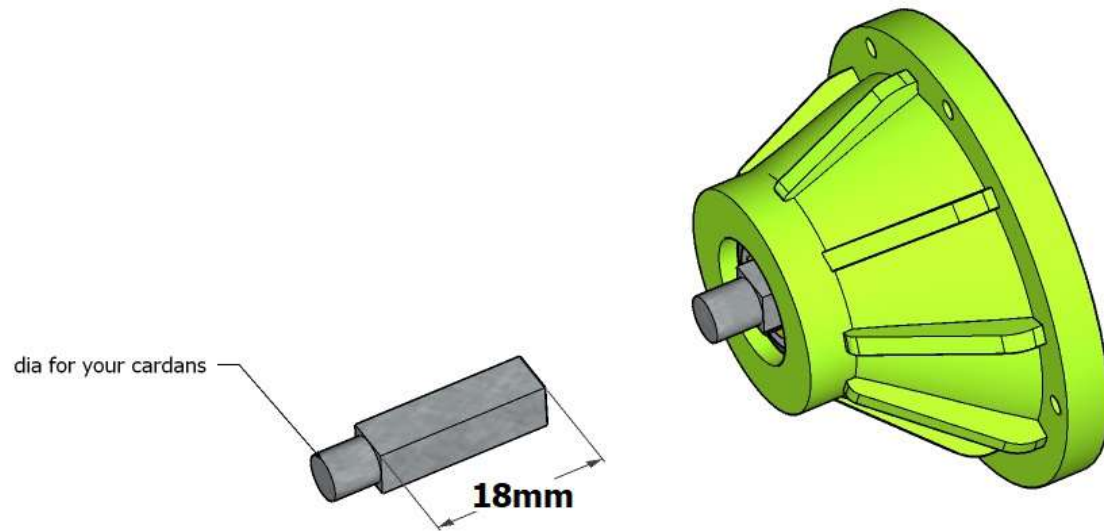

Step 24

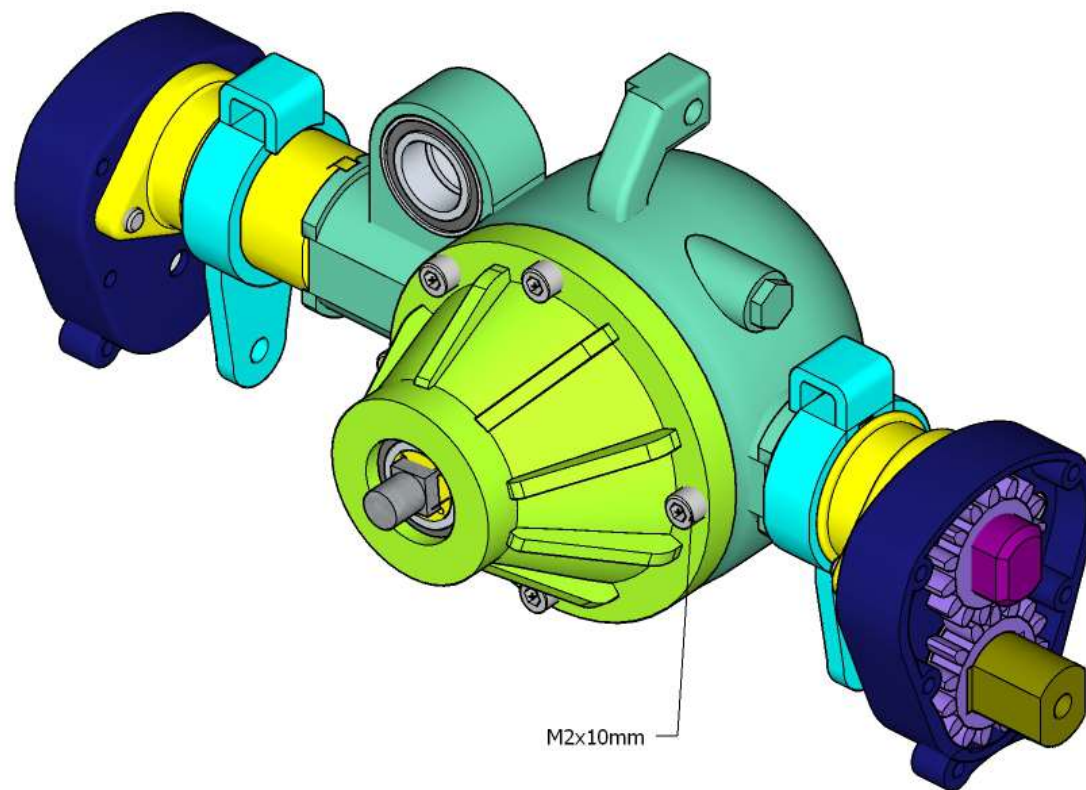

Step 25

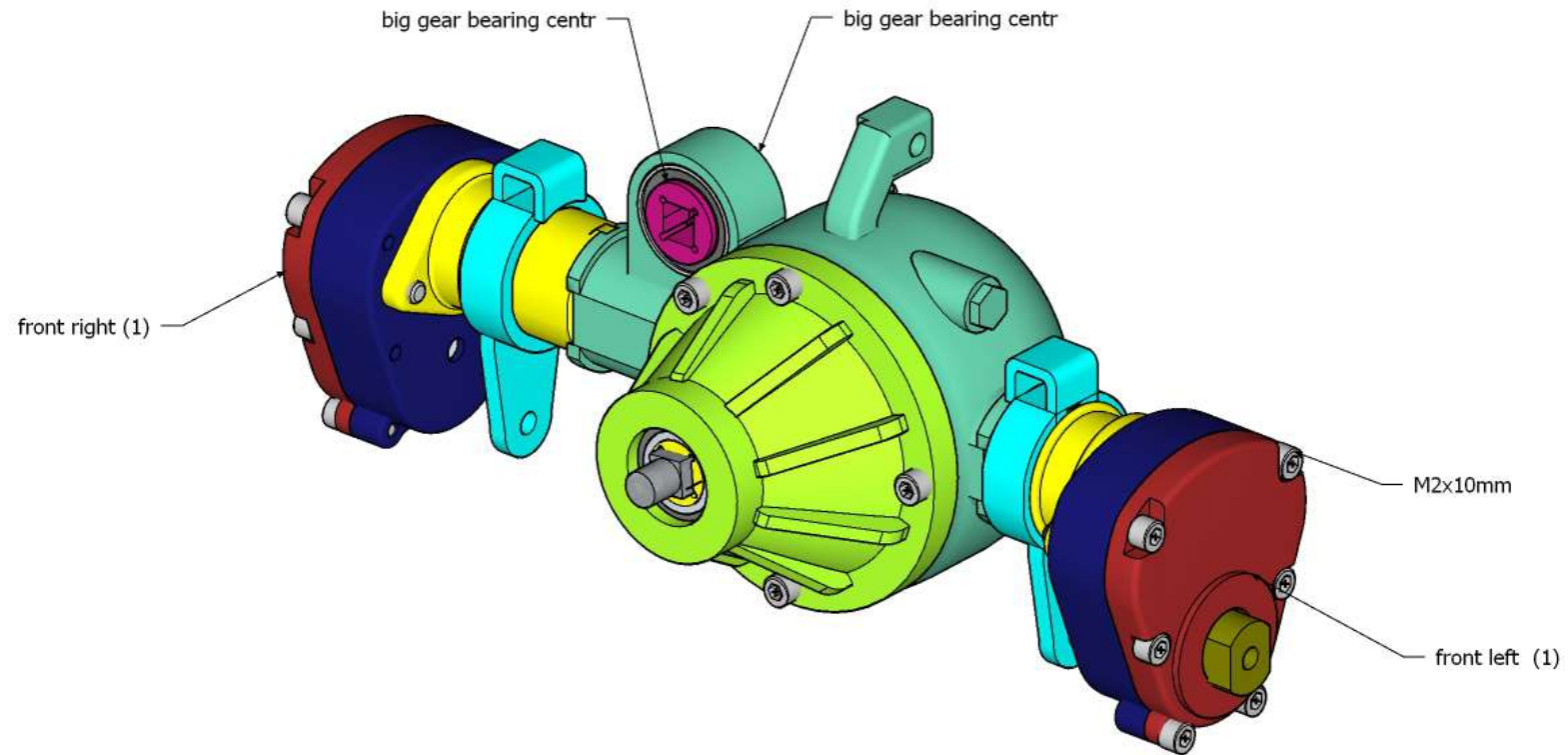

Step 26

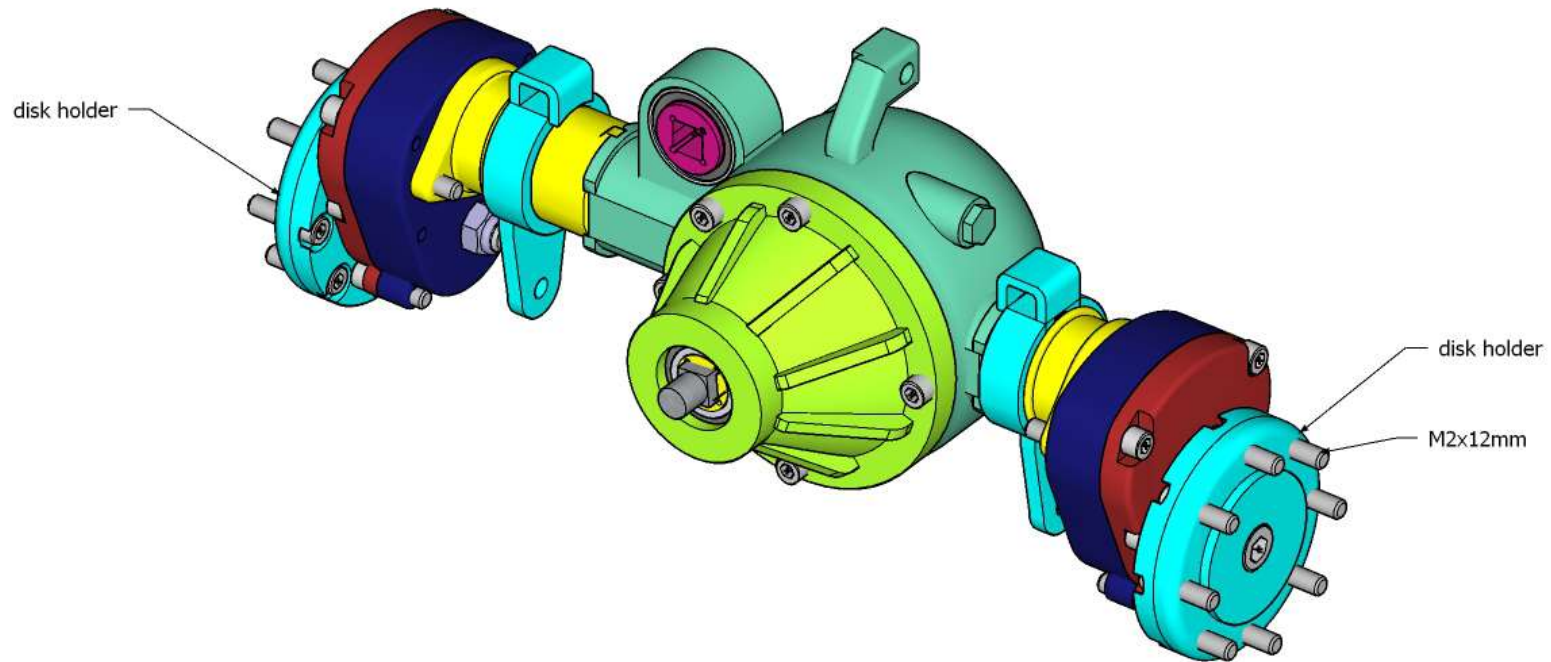

Step 27

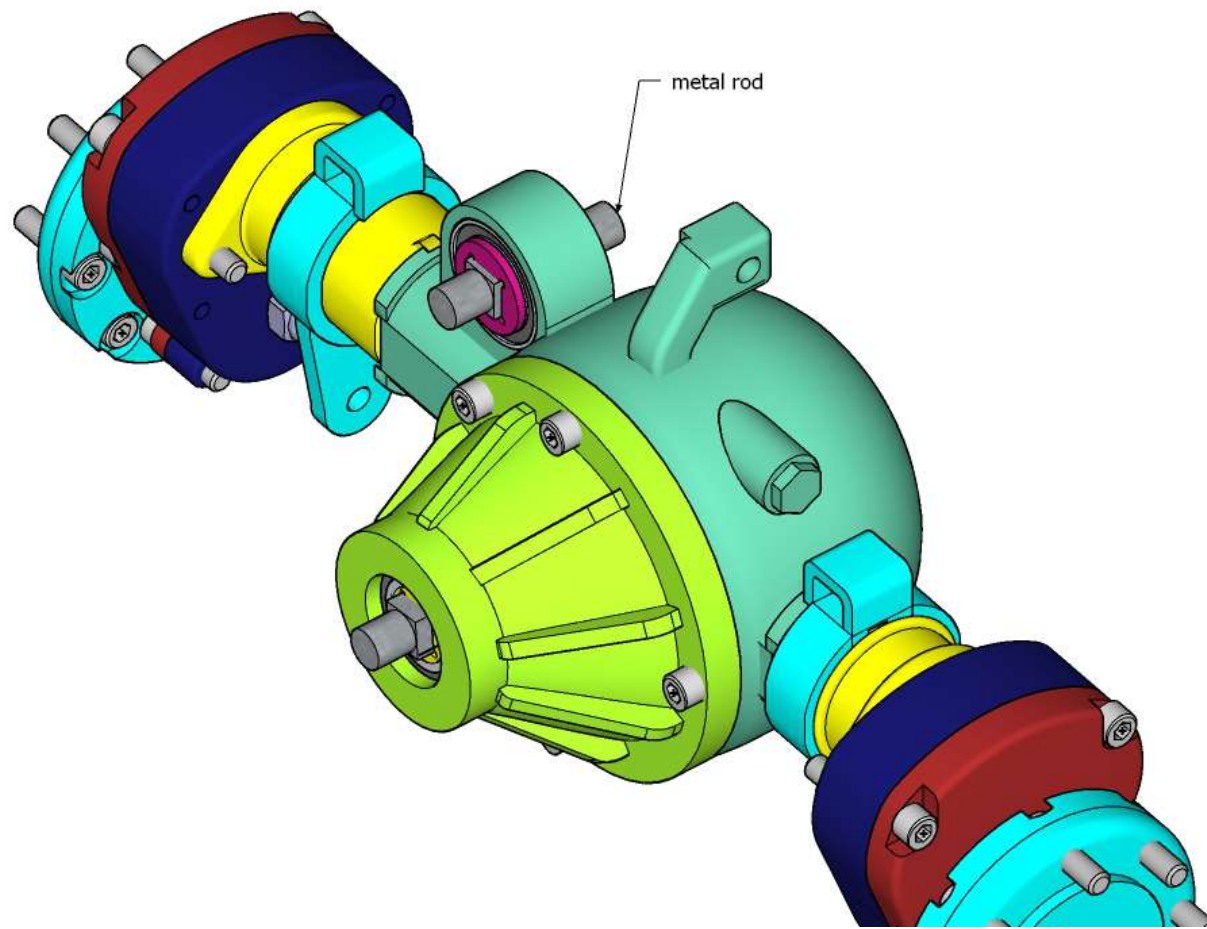

Step 28

Back axle second
the same procedure as for the previous axle,
just turn the half-axes and put the rear house as in the picture

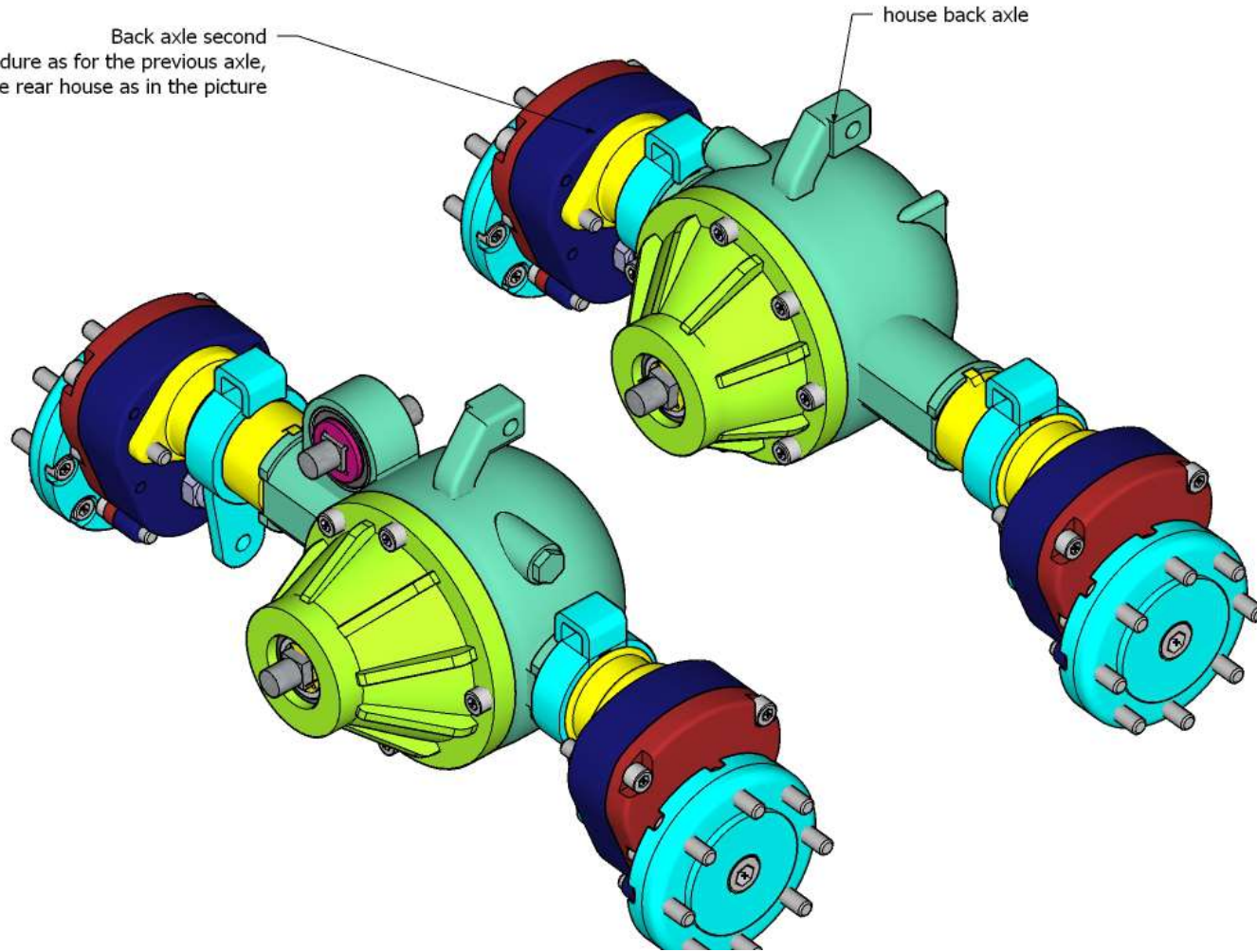

Step 29

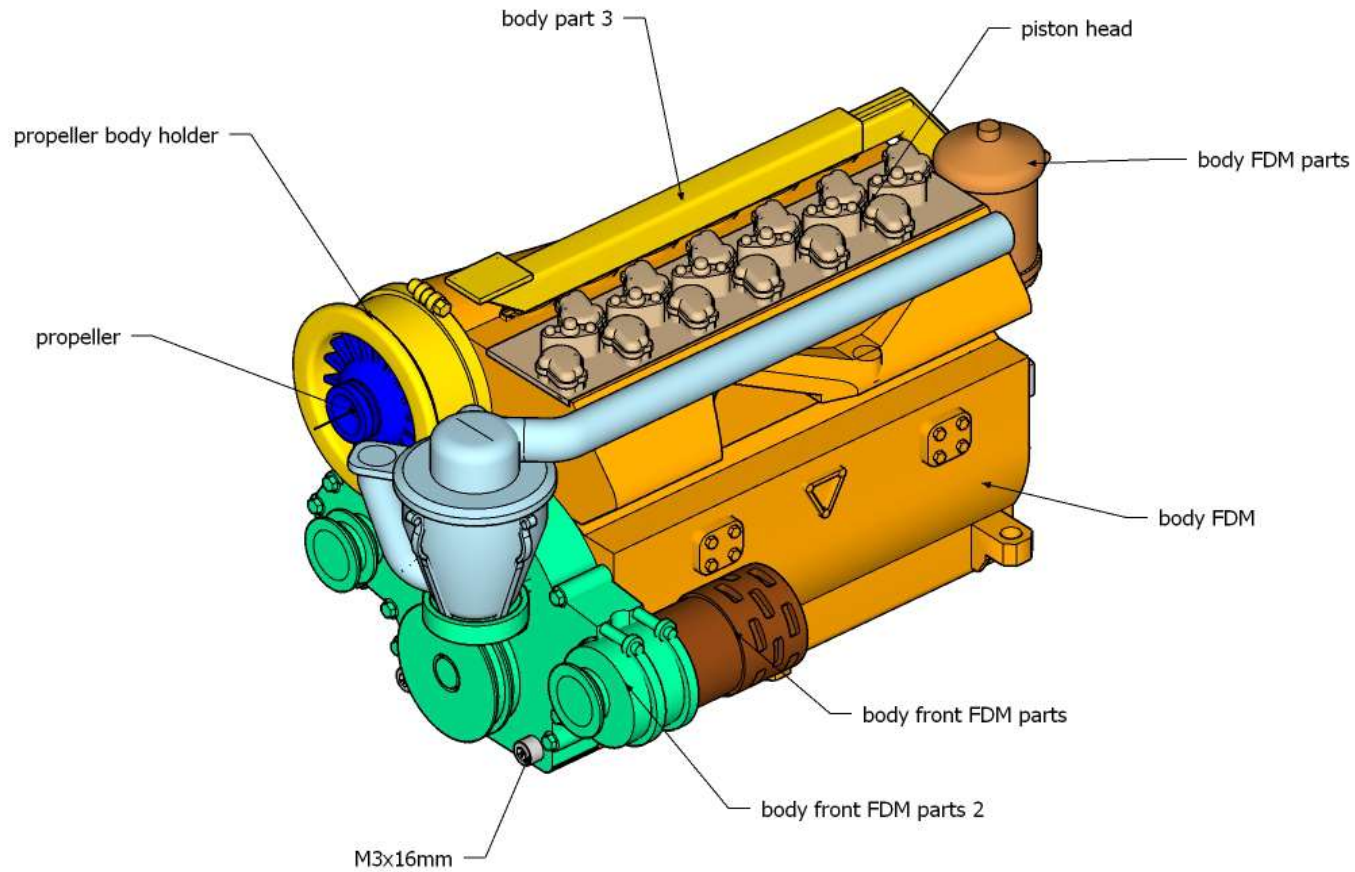

Step 30

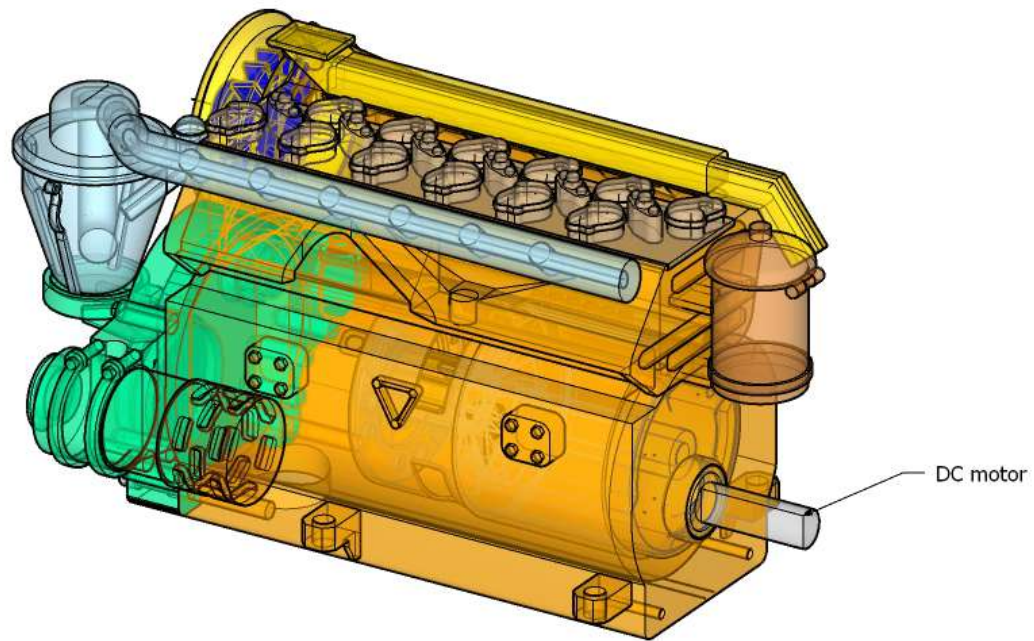

Step 31

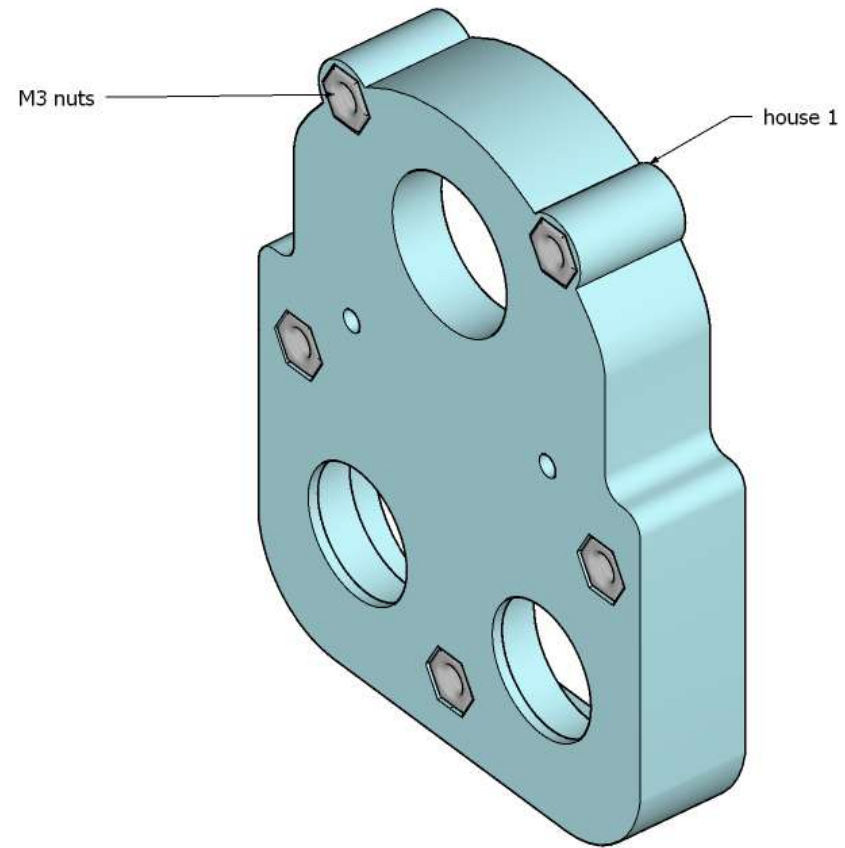

Step 32

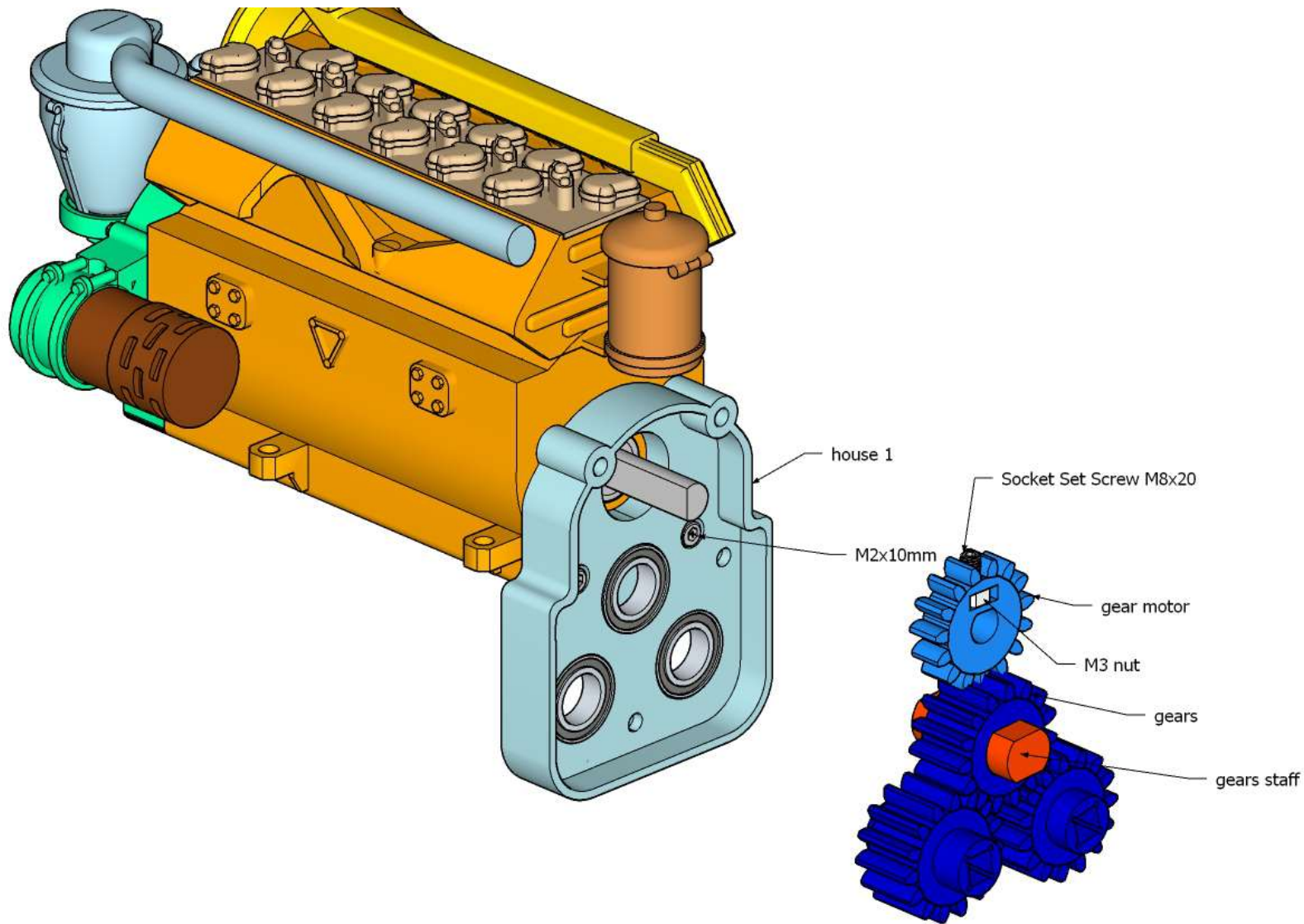

Step 33

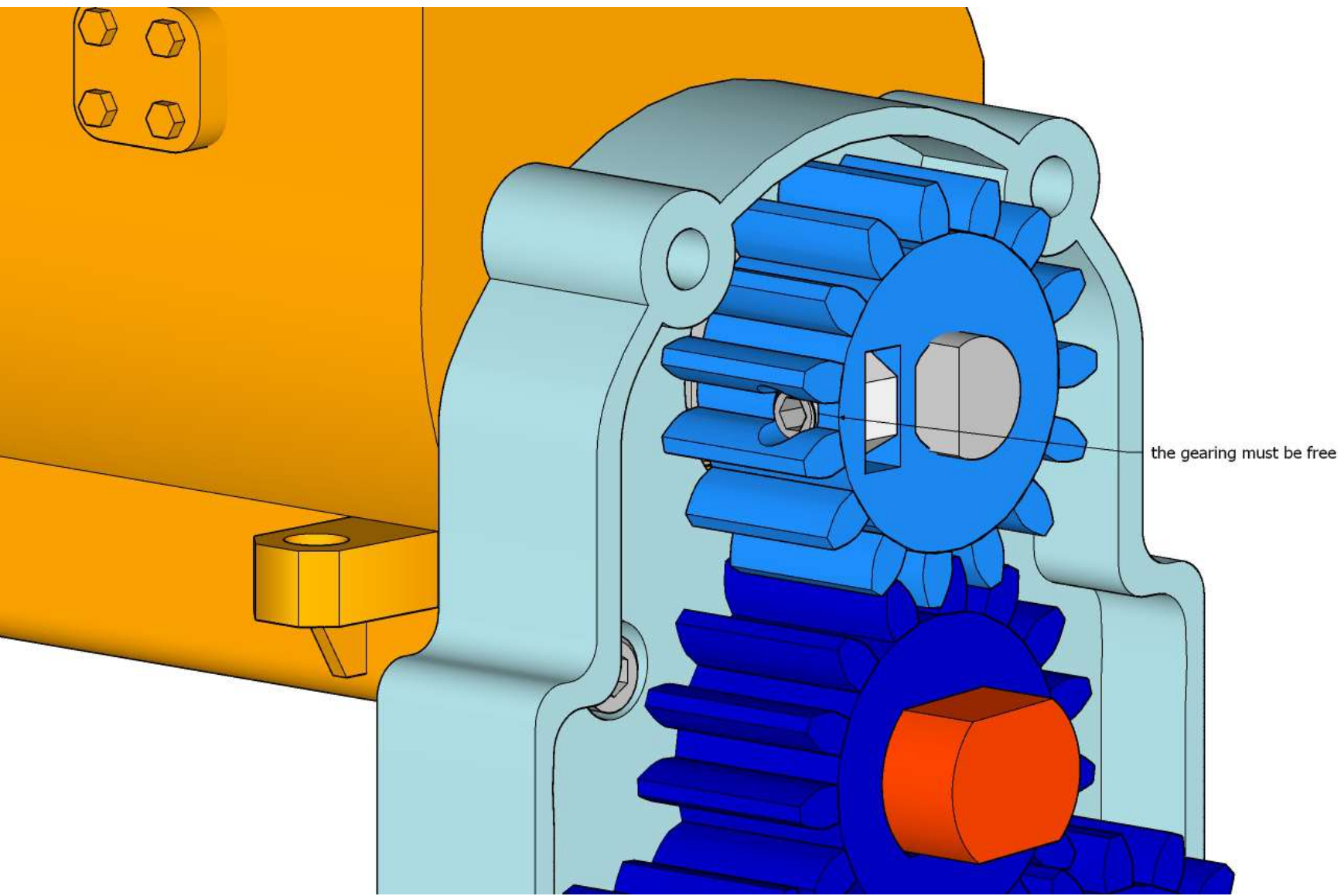

Step 34

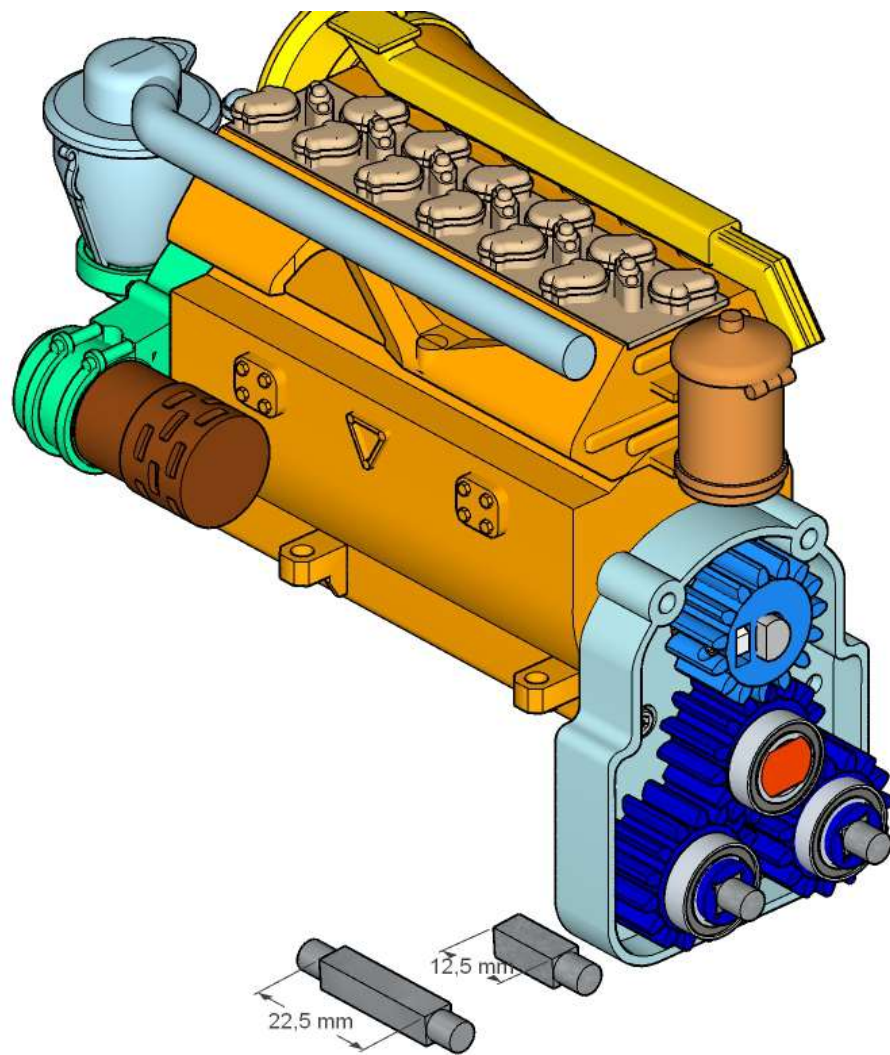

Step 36

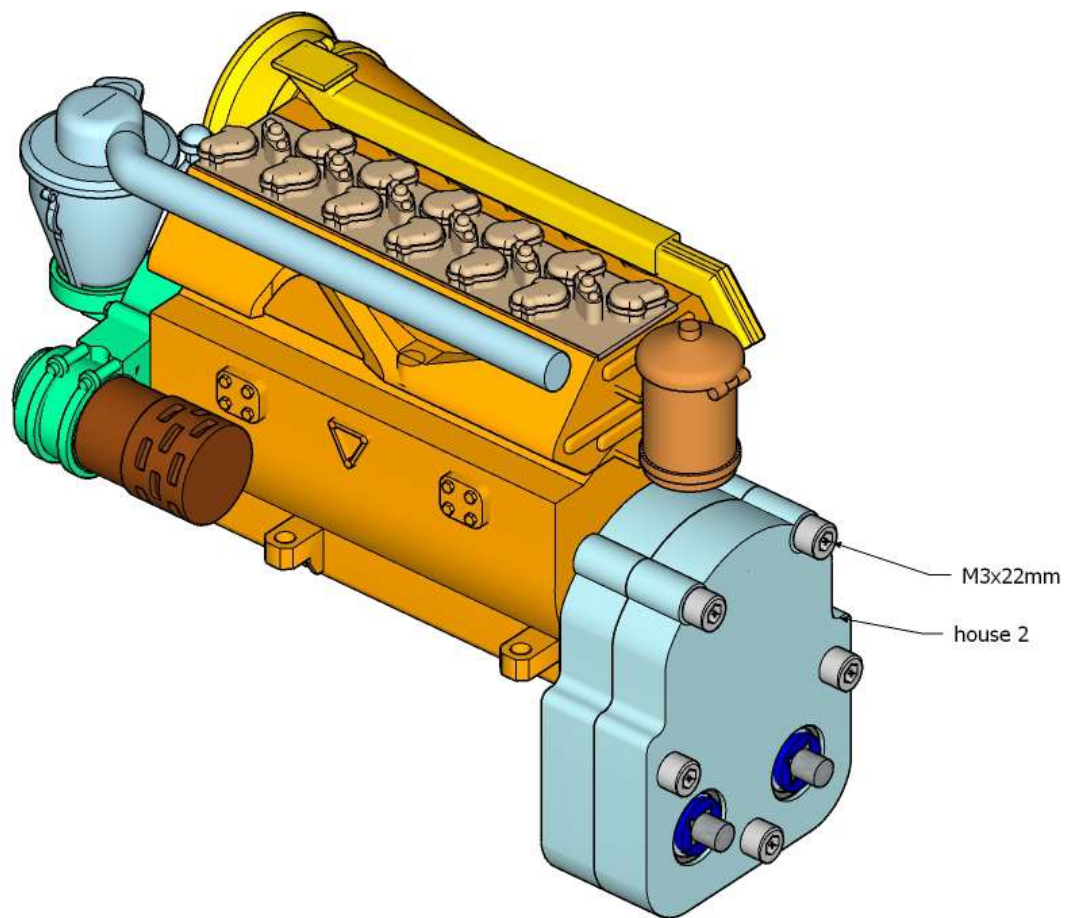

Step 35

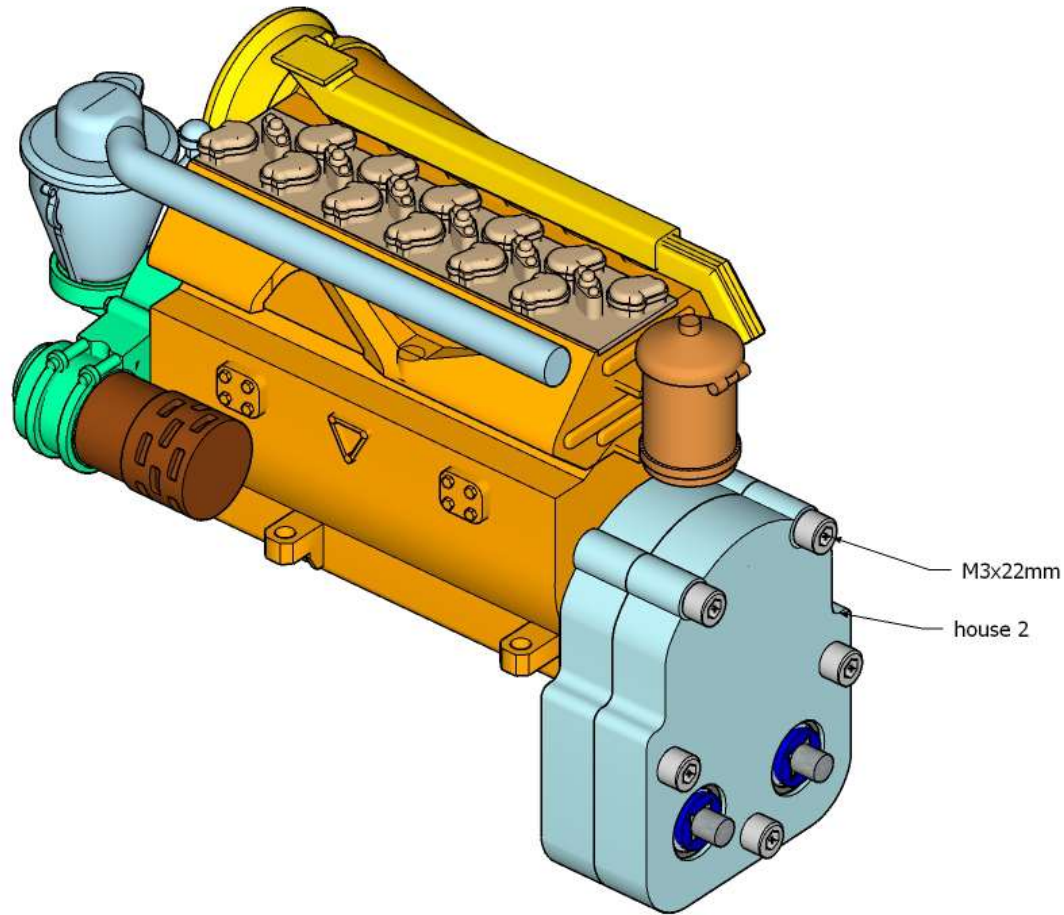

Step 36

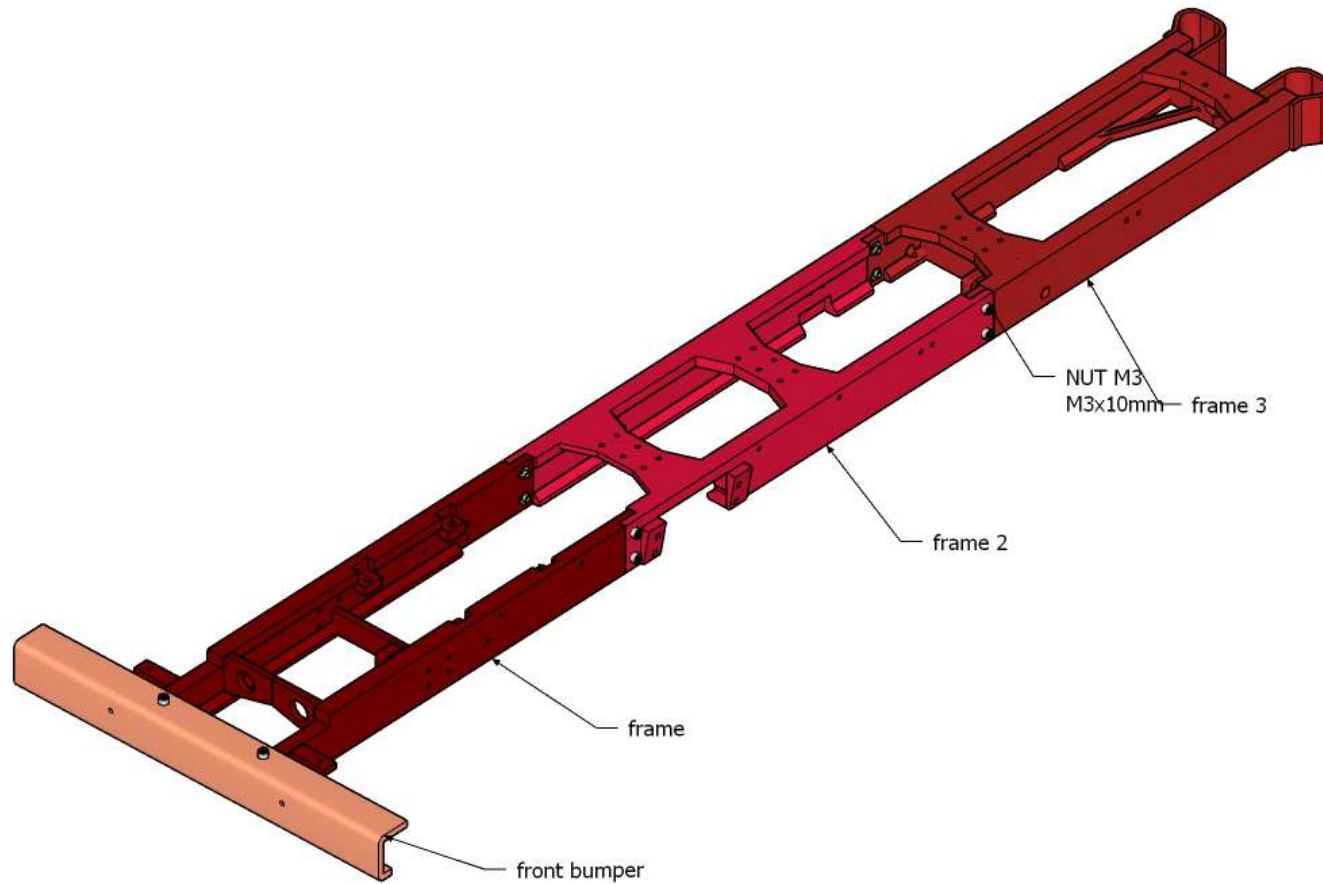

Step 37

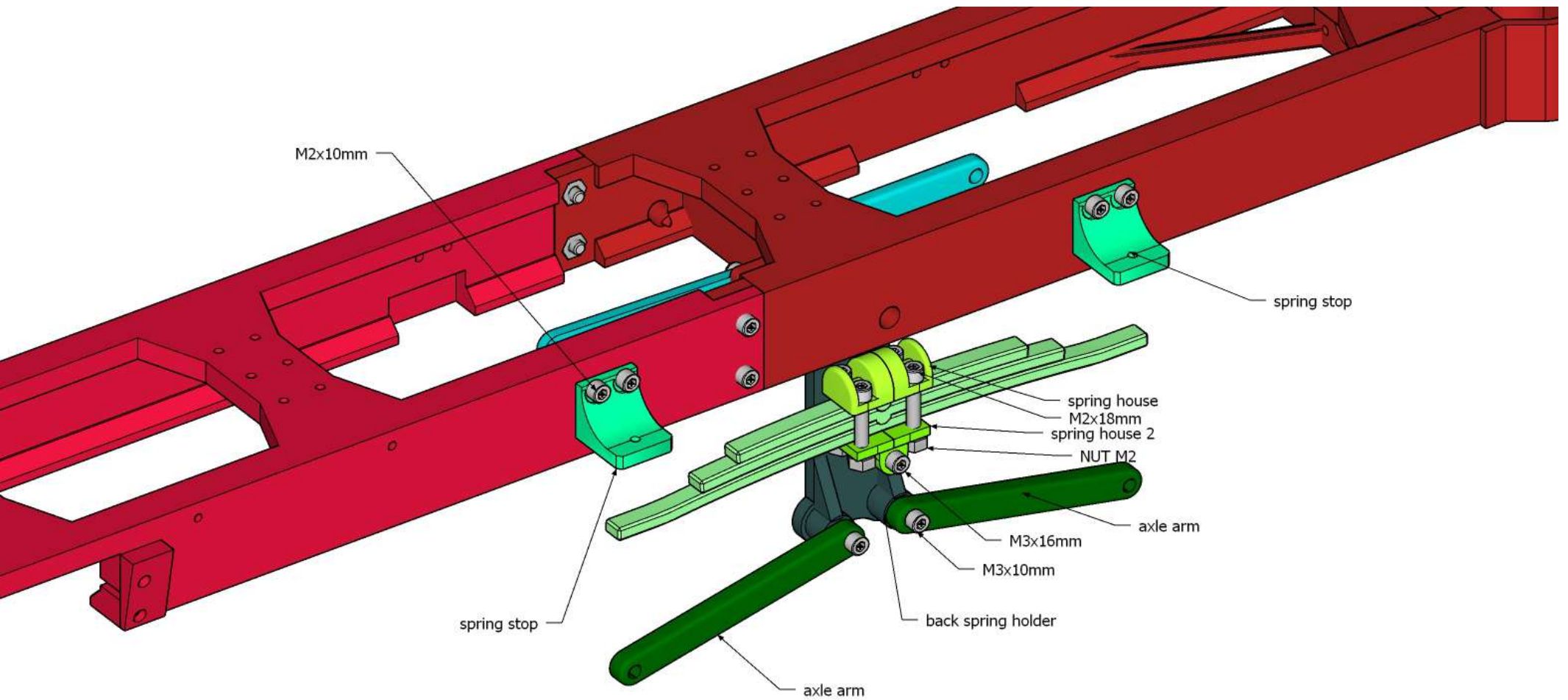

Step 38

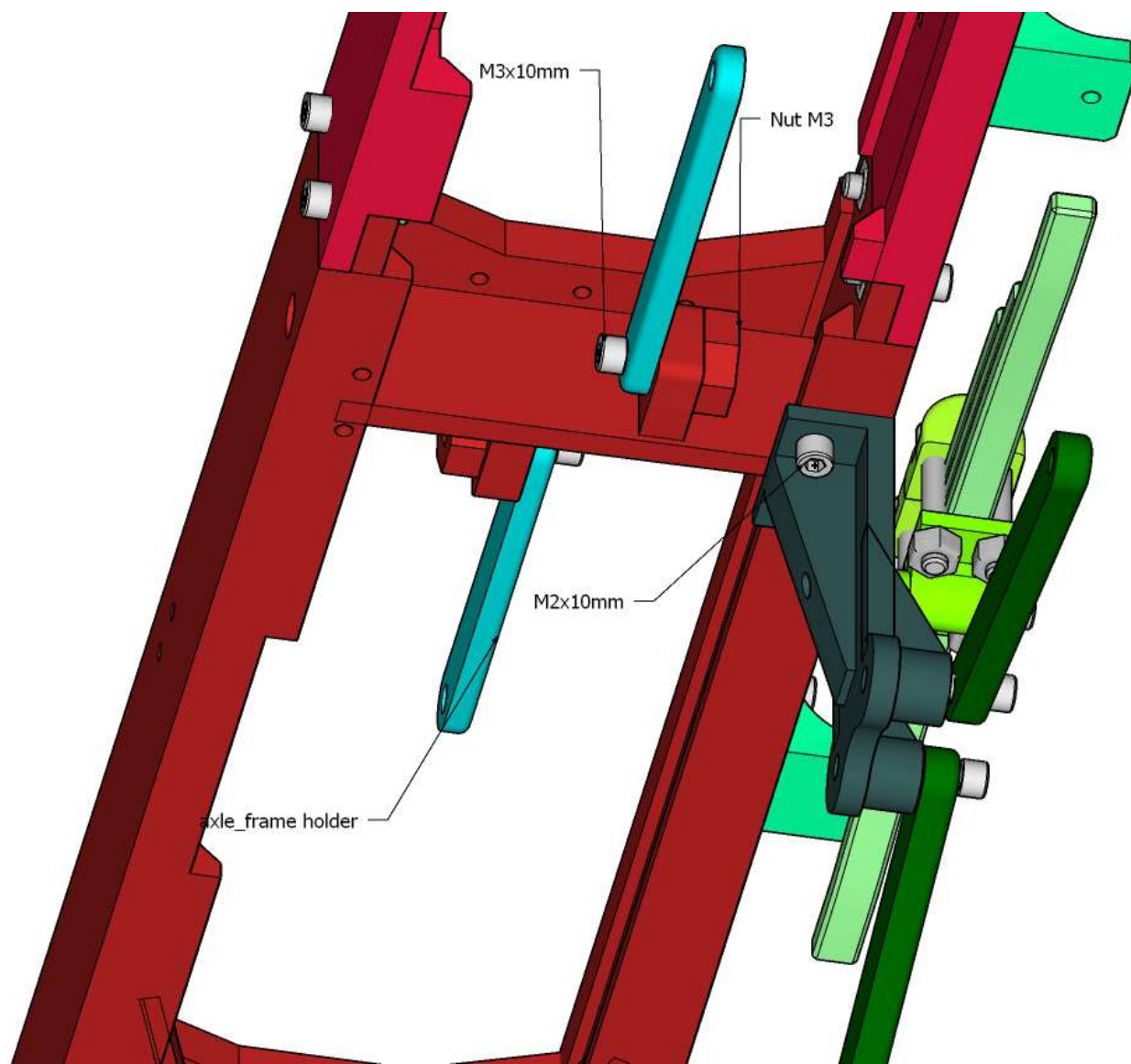

Step 39

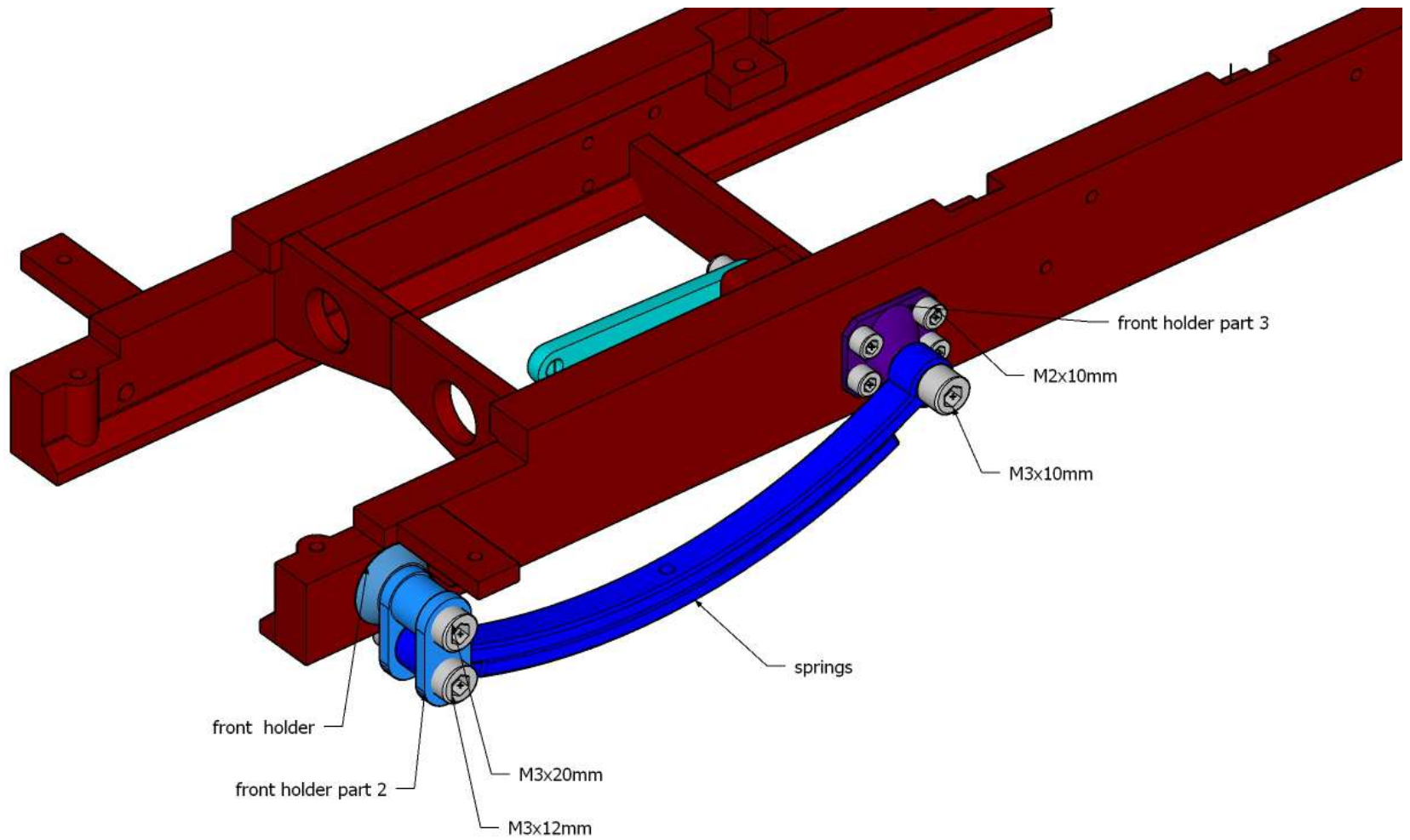

Step 40

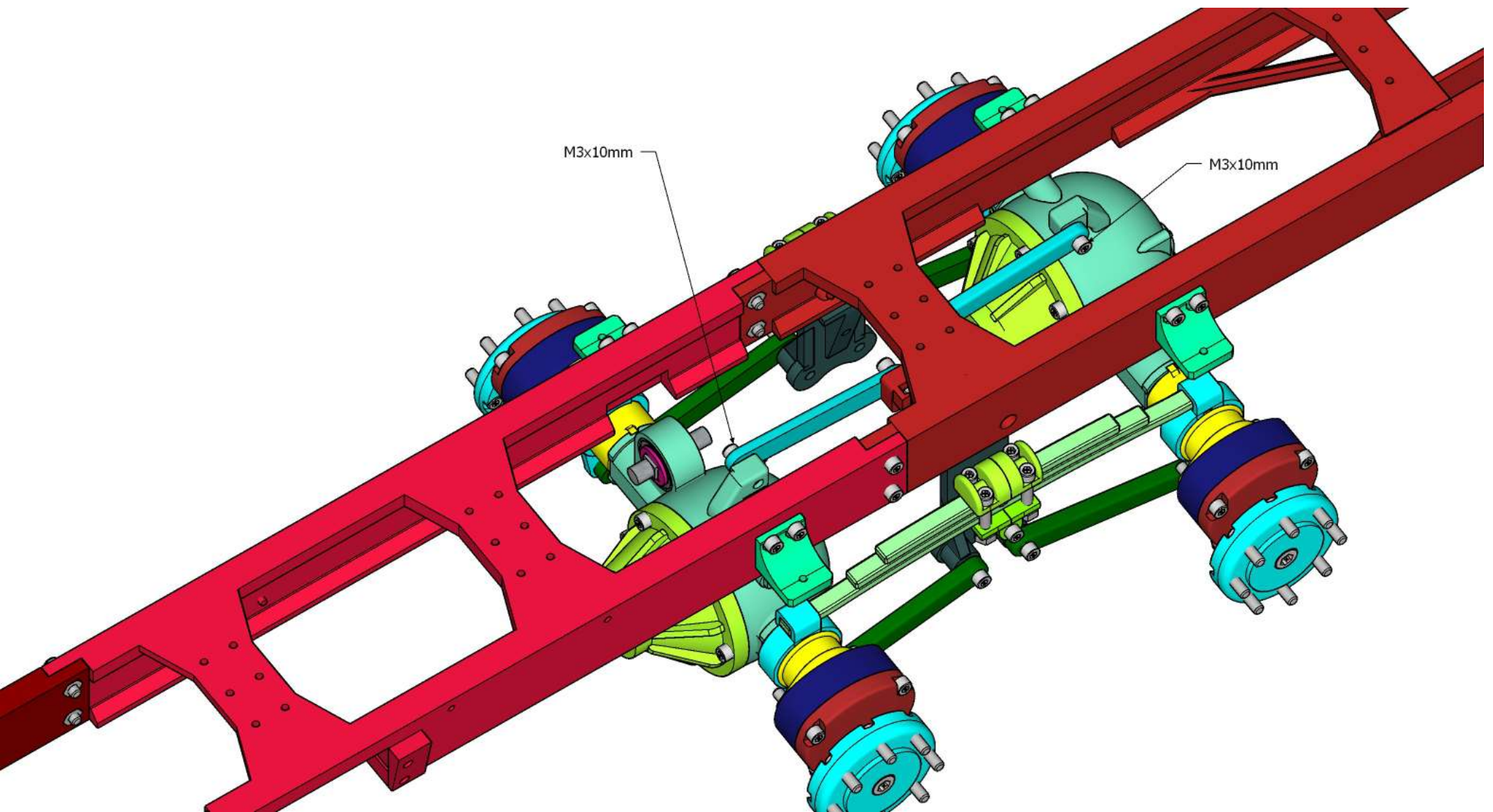

Step 41

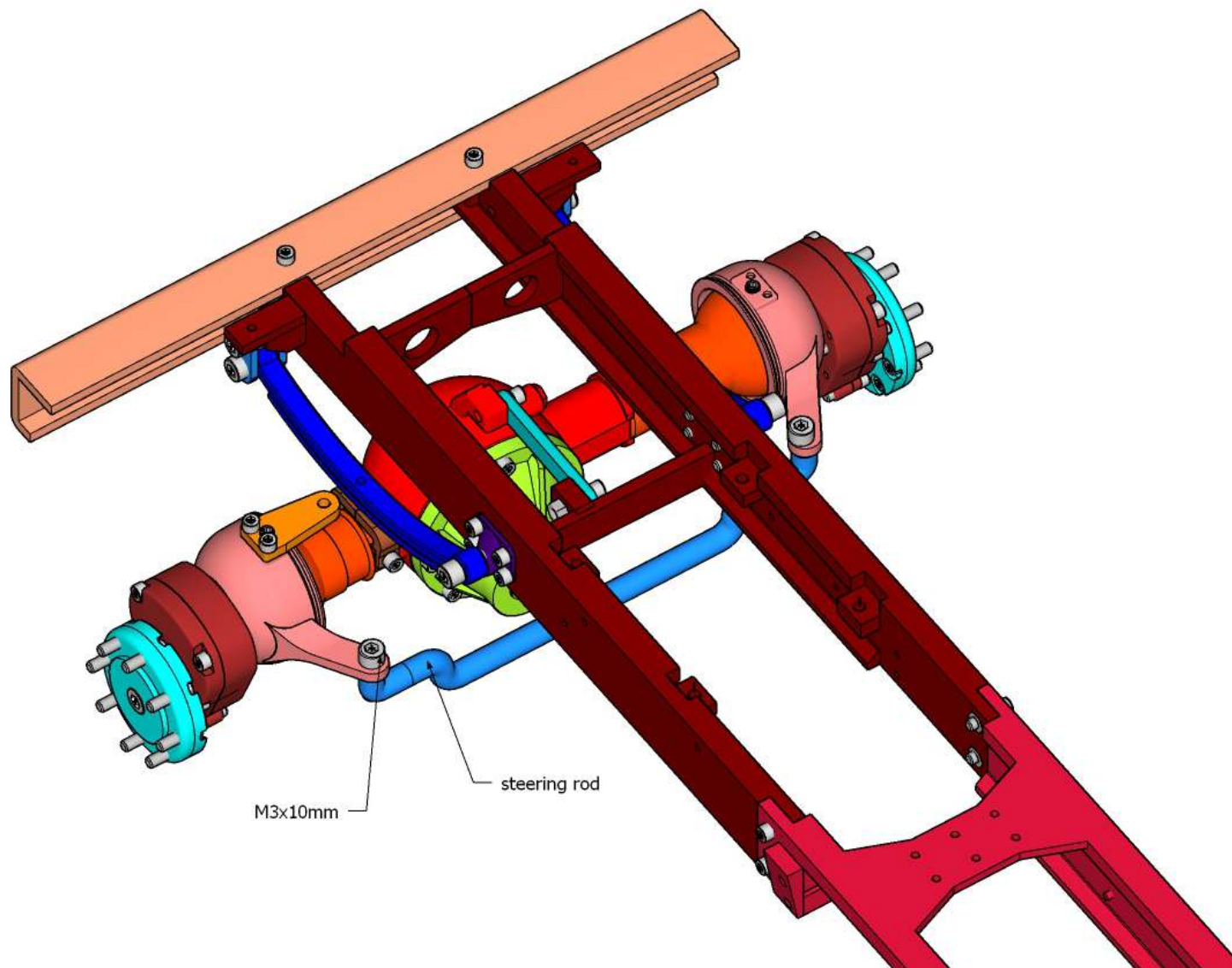

Step 42

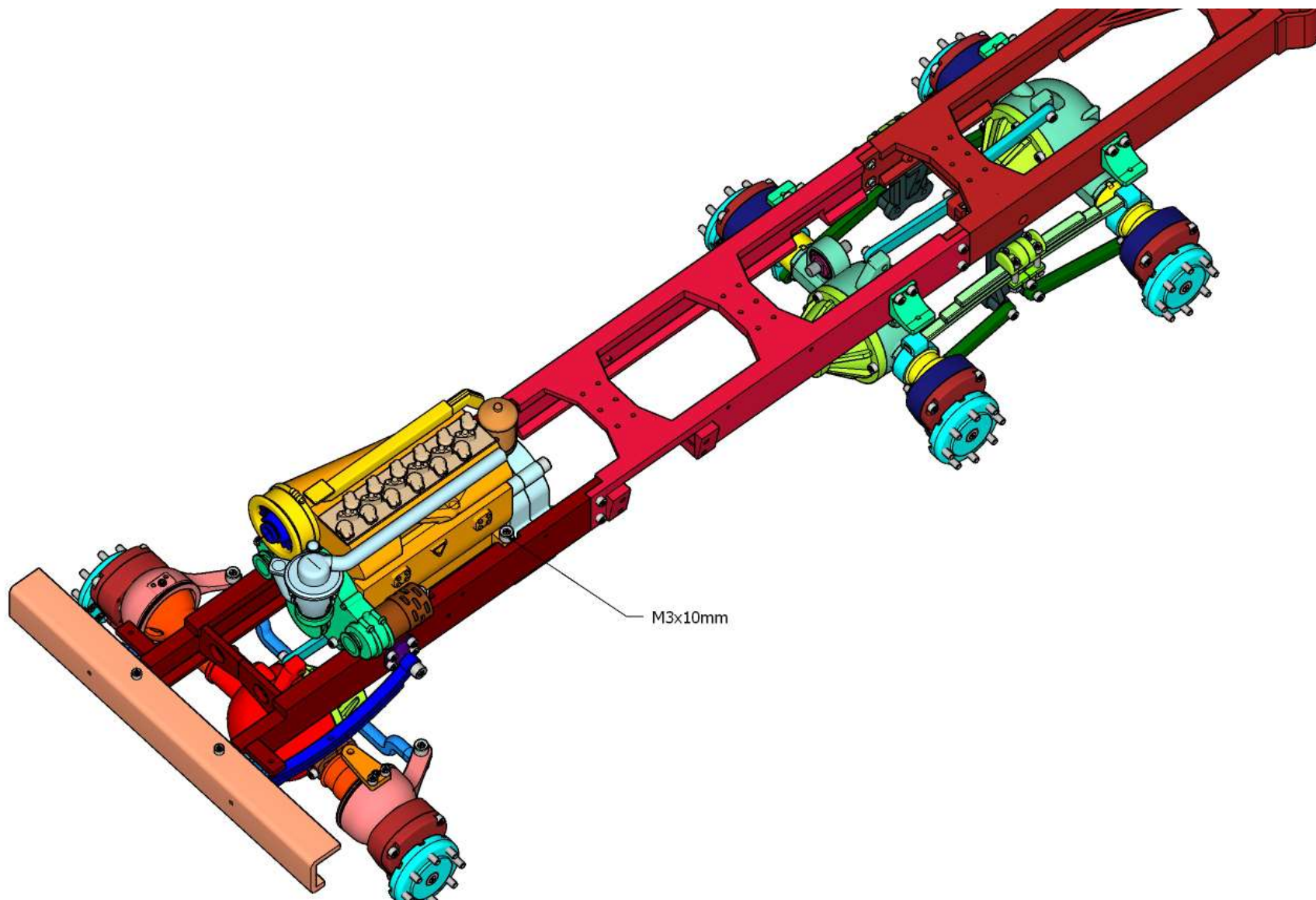

Step 43

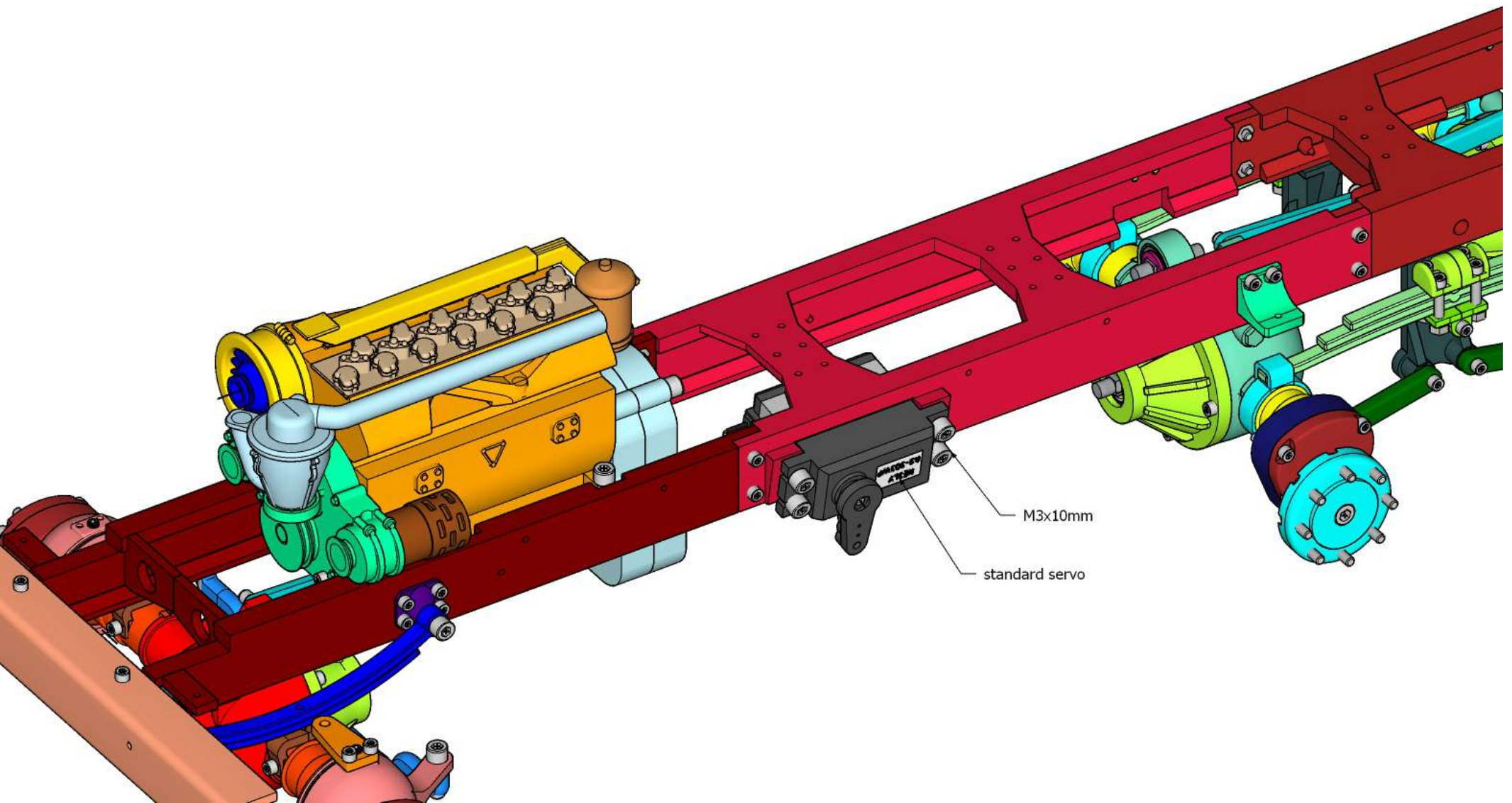

44

