

Excavator 1/10 RC



You will need:

- screws M3 x 10 mm – 50 pcs
- screws M3 x 16 mm – 30pcs
- screws M3 x 25 mm – 50pcs
- screws M3 x 40 mm – 15pcs
- screws M3 x 50 mm – 5pcs
- screws M3 x 8 mm – 10pcs
- screws M2 x 5 mm – 100pcs
- screws M2 x 10 mm – 100pcs
- screws M2 x 25 mm – 20pcs
- Nut M4 – 20pcs
- Nut M2 – 20pcs
- Motors:
<https://www.laskakit.cz/motor-jga25-370-12v-s-prevodovkou-/?variantId=6861> -3x 150RPN

<https://www.laskakit.cz/ga12-n20-motor-s-prevodovkou-12v-500rpm-se-snekem-m4x55mm/> - 5x
- Servo:
<https://www.laskakit.cz/plastove-micro-servo-sg90-9g--kontinualni/> - for shovel 360 rotary if you can buy, I recommend metal.
Servo odporúčam kovové , avšak je veľmi málo skladom v obchodoch

platform servo:
<https://www.laskakit.cz/servo-mg995-s-kovovymi-prevody-kontinualni-extra-silne/> - 360 rotary
- <https://www.laskakit.cz/trapezova-tyc-t8x8-400mm/> -3x
- <https://www.laskakit.cz/matice-pro-trapezovou-tyc-t8x8--mosaz/> -3x
- Regulators for motors : <https://www.conrad.sk/p/absima-auto-brushed-zatazitelnost-max-180-a-2160921> - 4x

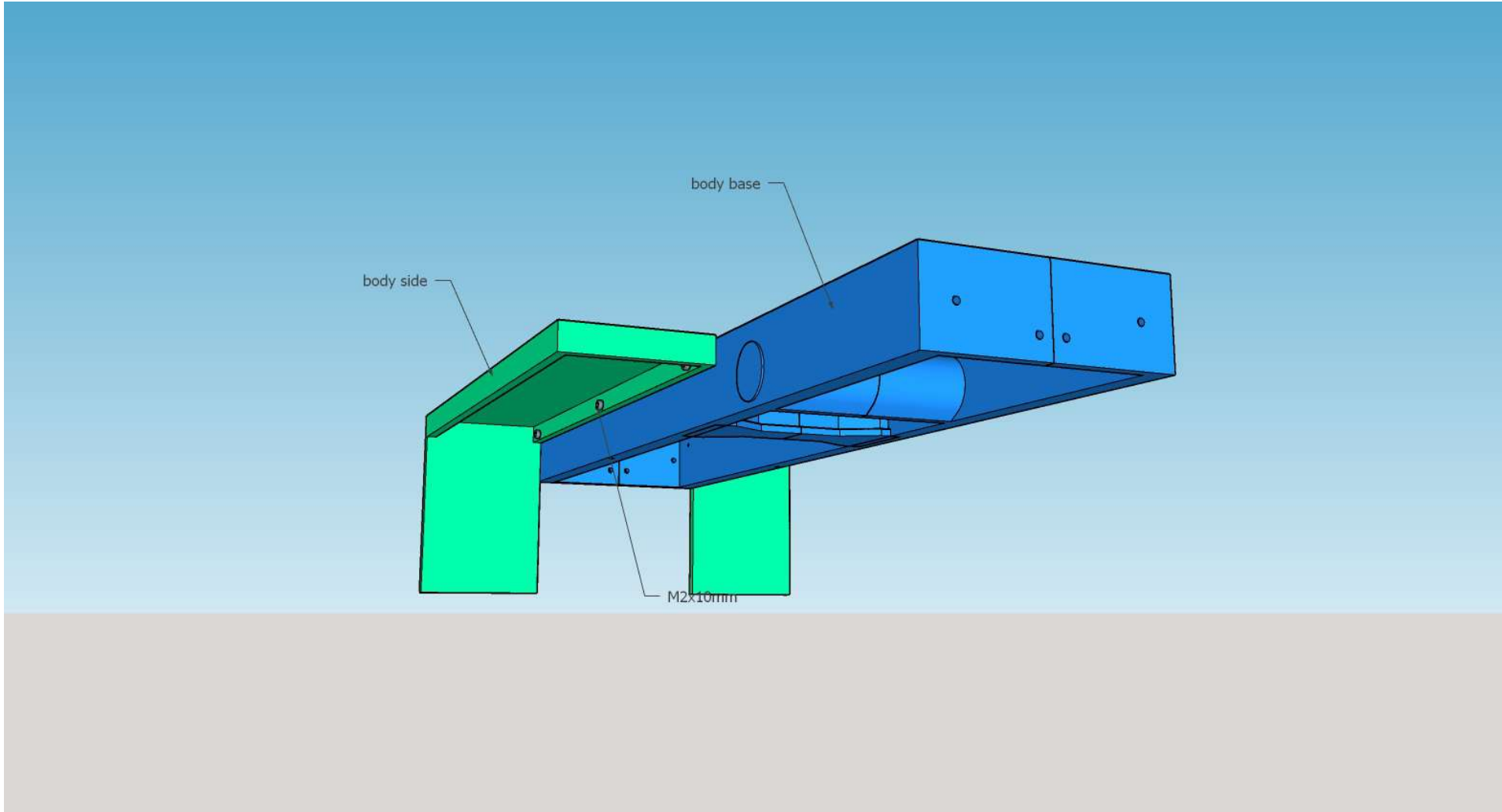

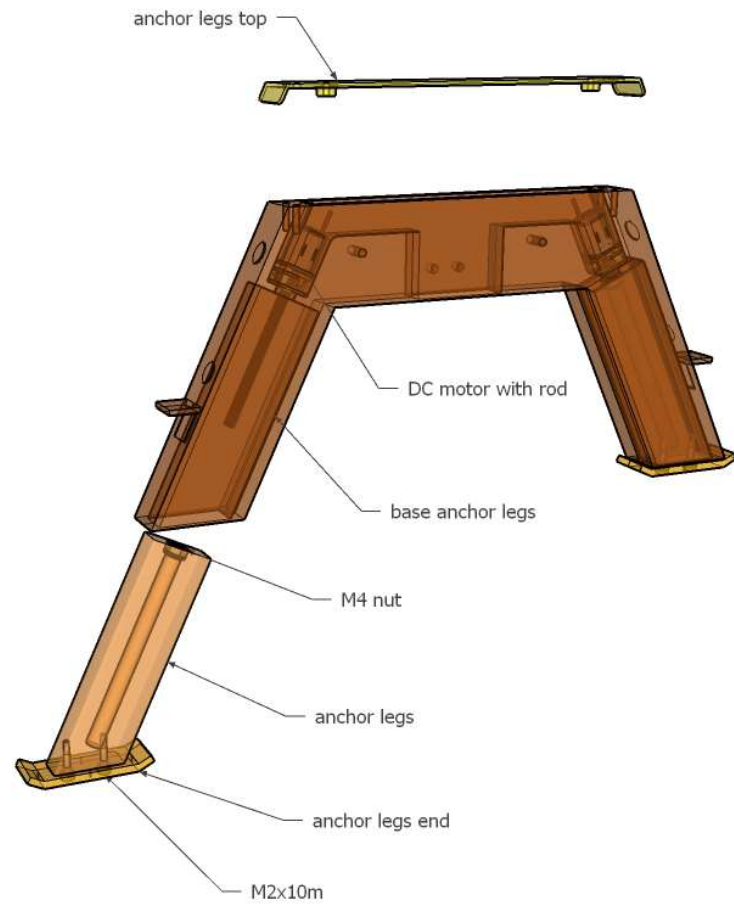

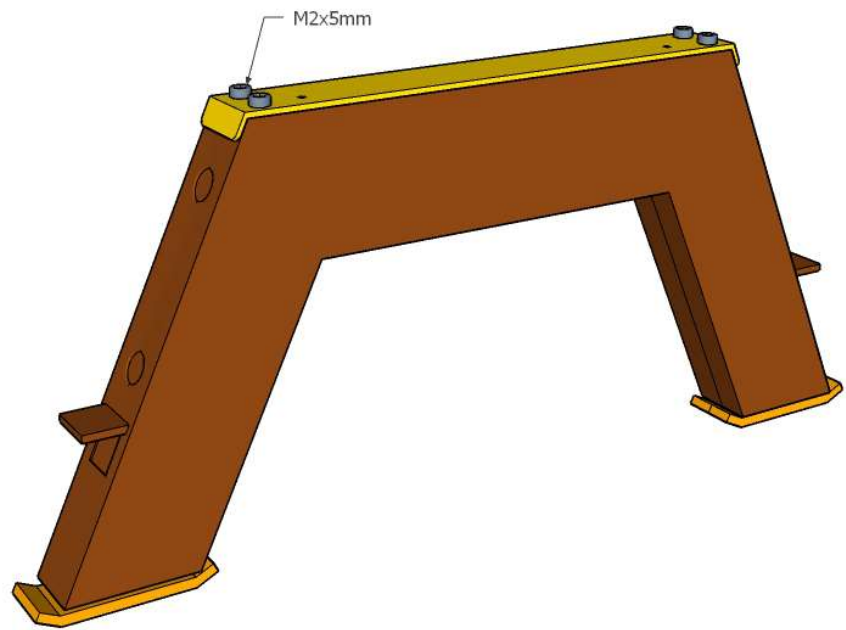

M2x5mm

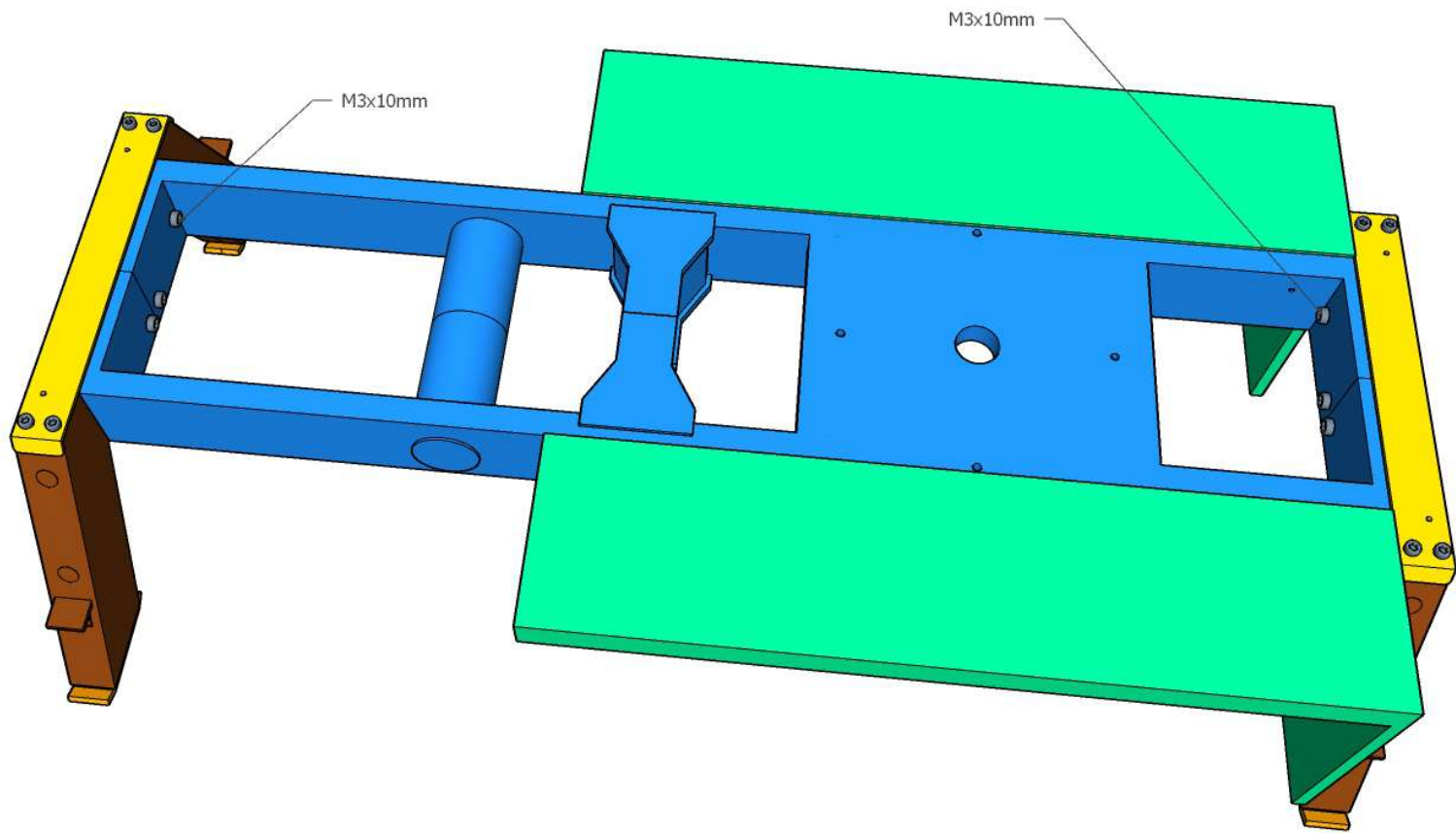

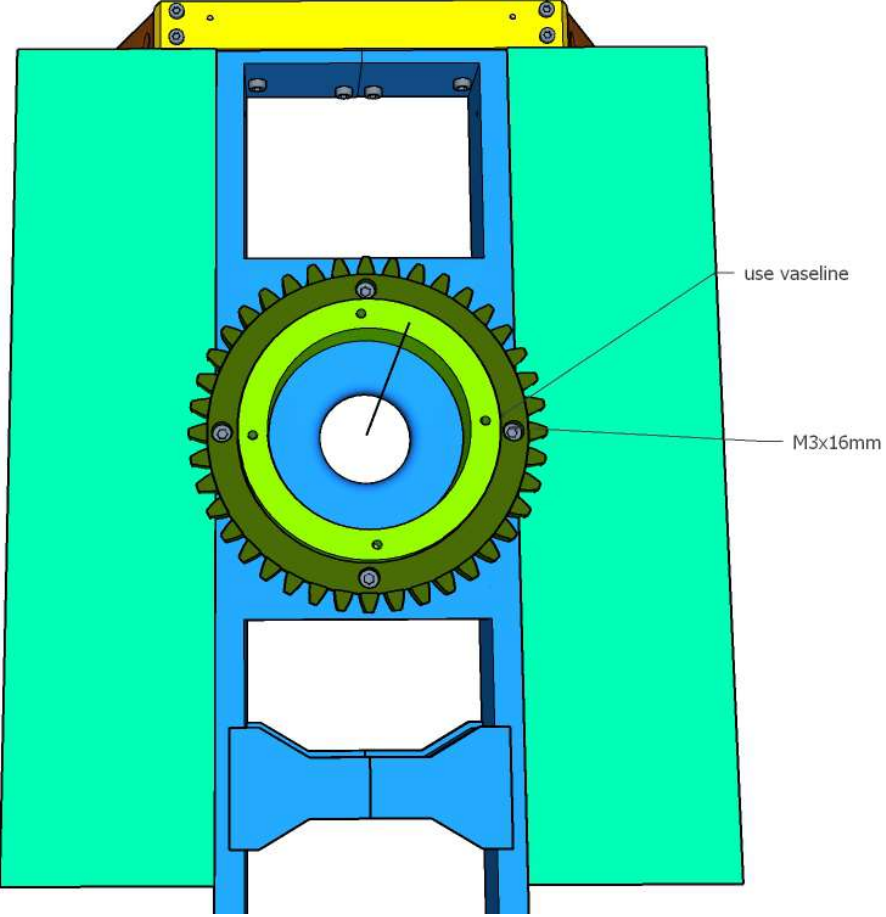

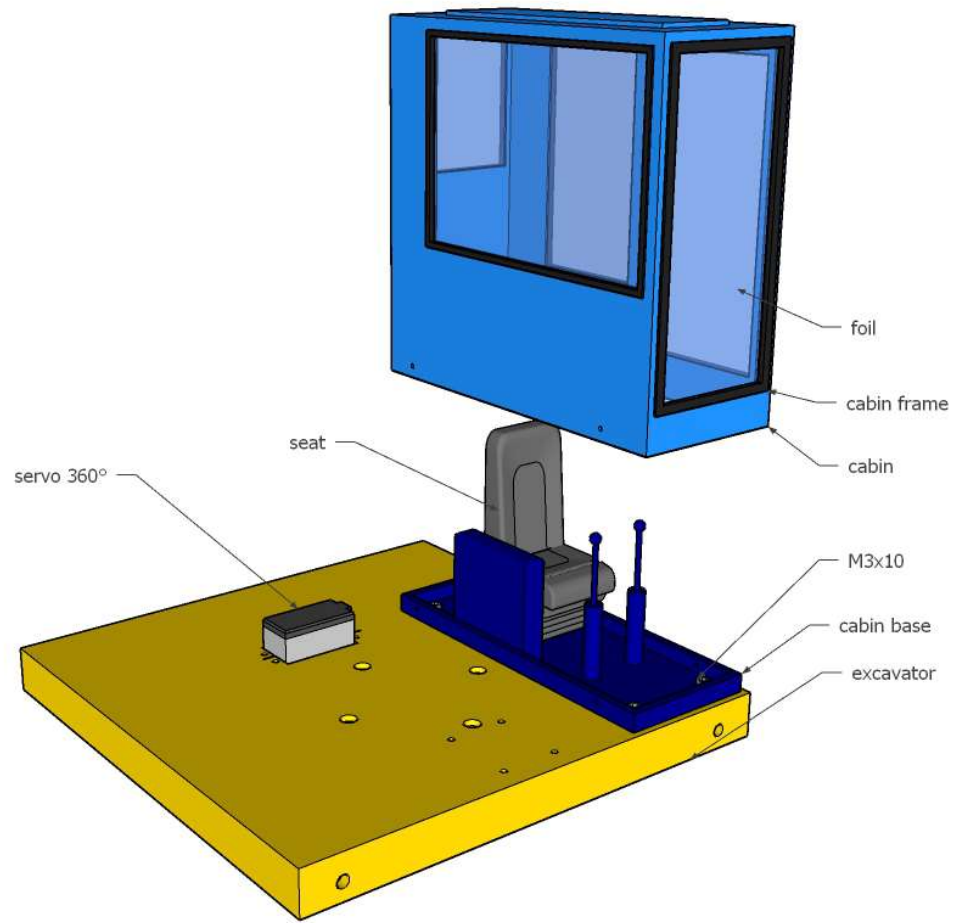

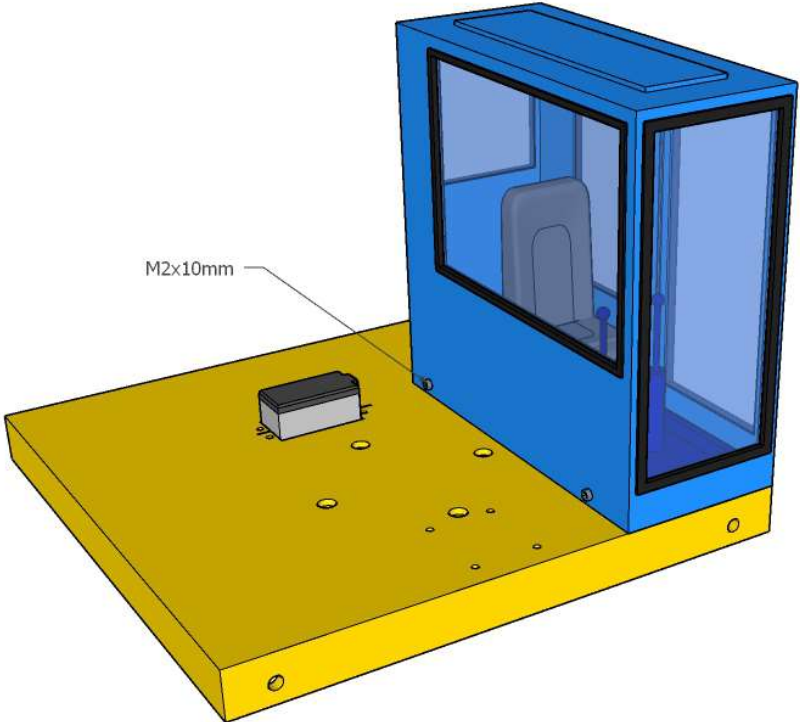

M2x10mm

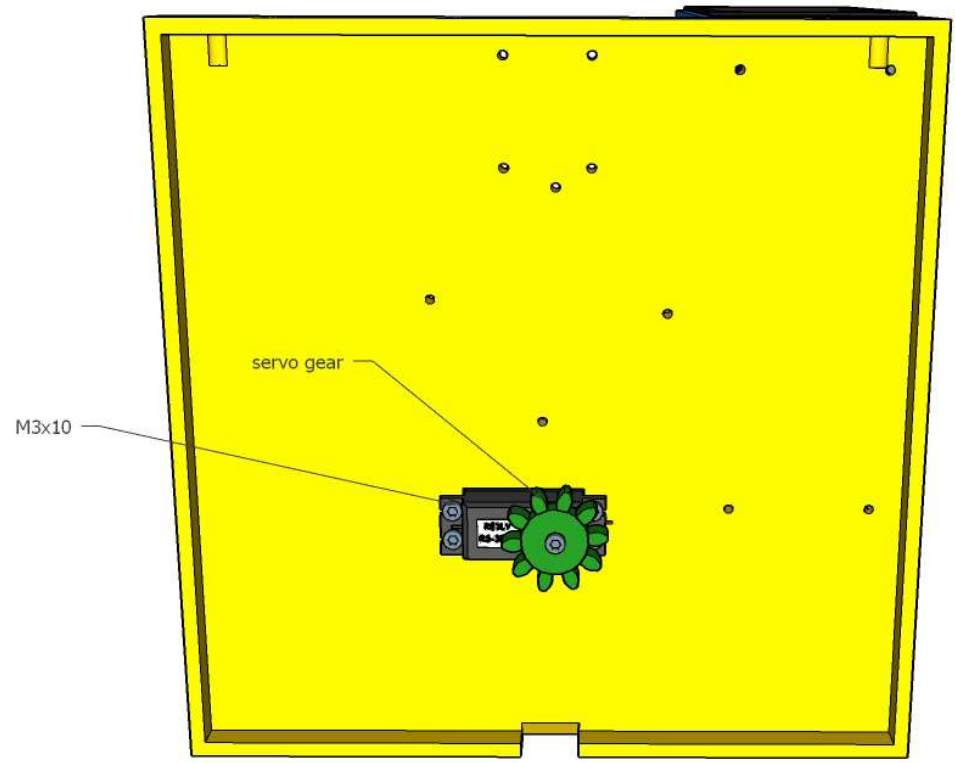

box 1 and 2
- use glue

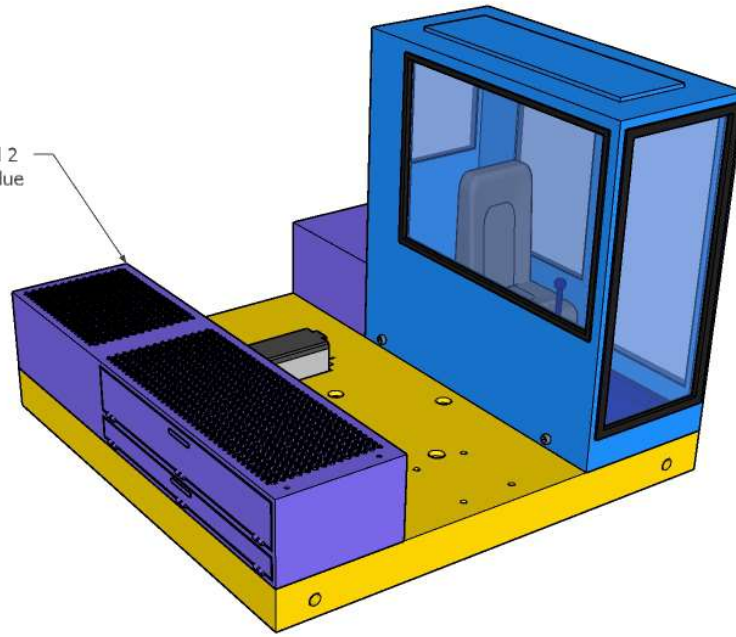

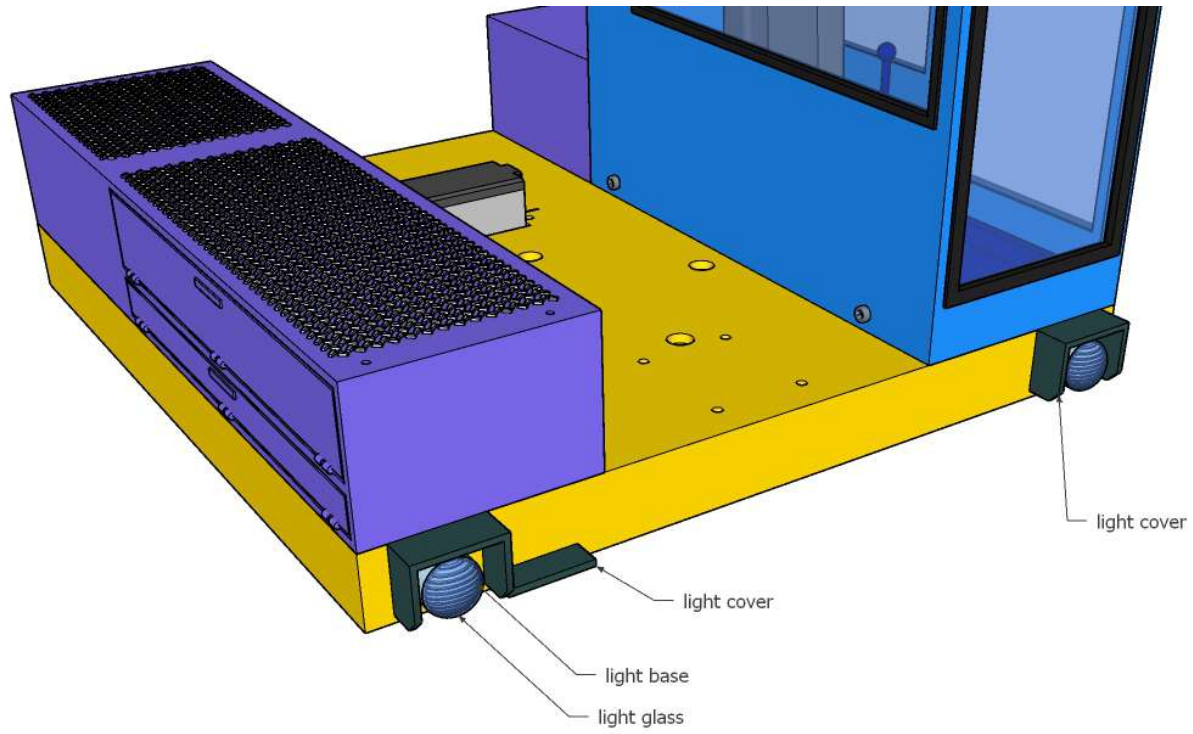

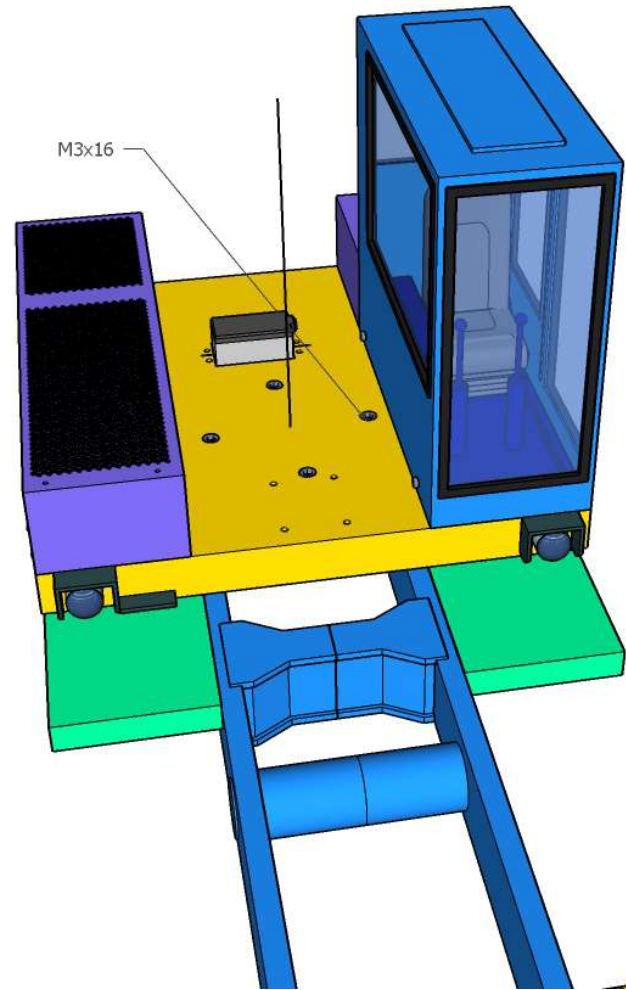

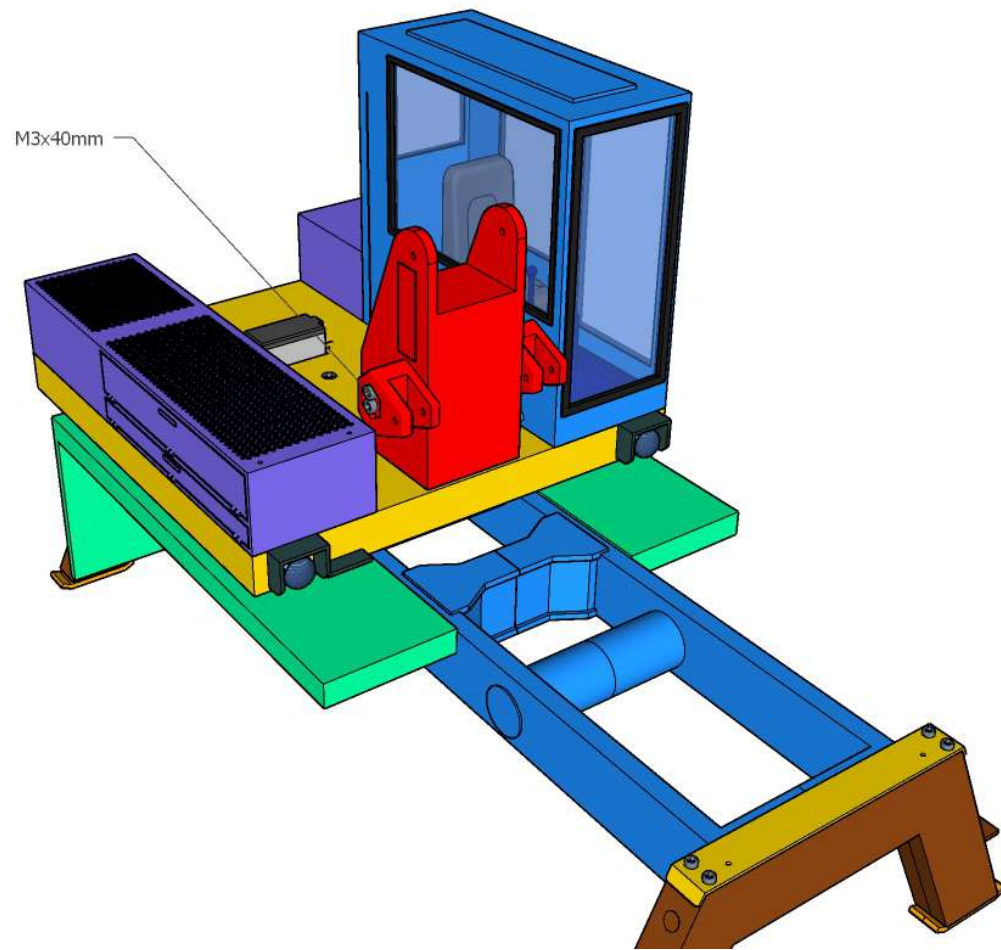

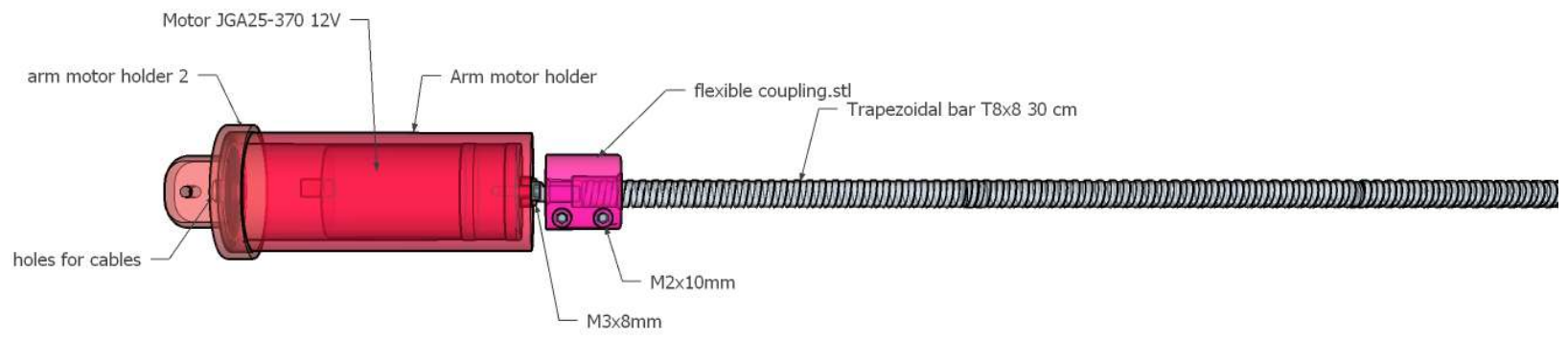

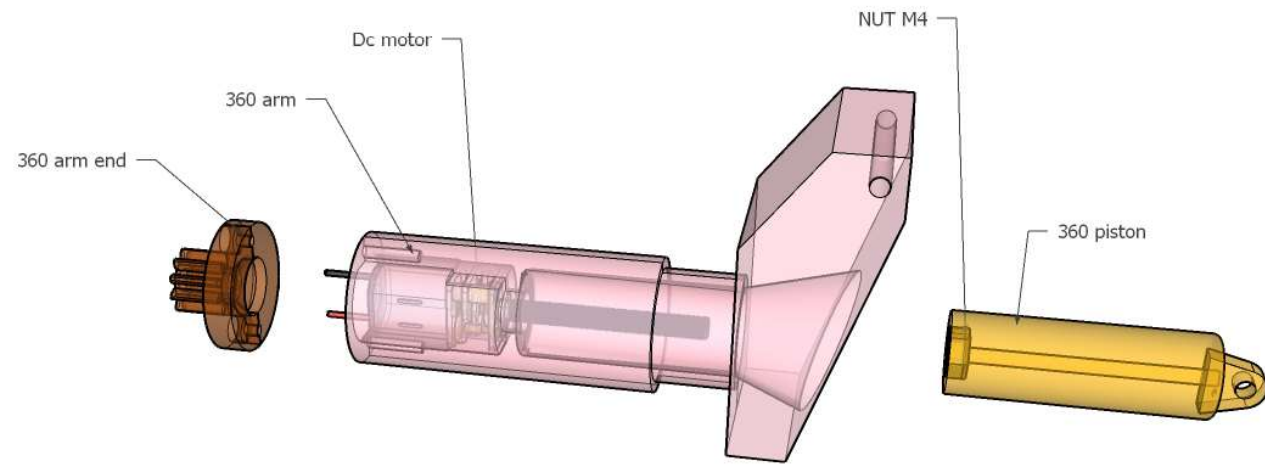

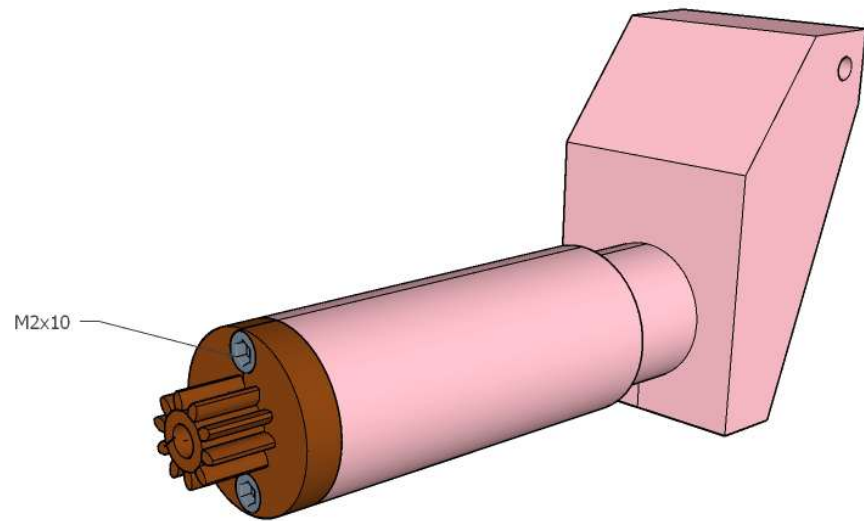

M2x10

